

High Strength Bolting



for Canadian Engineers

G.L. Kulak, Ph.D., P.Eng.

Department of Civil Engineering
University of Alberta
Edmonton, Alberta

cisc  icca

High Strength Bolting for Canadian Engineers

G.L. Kulak, Ph.D., P.Eng.

Department of Civil Engineering
University of Alberta
Edmonton, Alberta



CANADIAN INSTITUTE OF STEEL CONSTRUCTION
INSTITUT CANADIEN DE LA CONSTRUCTION EN ACIER
201 CONSUMERS ROAD, SUITE 300
WILLOWDALE, ONTARIO M2J 4G8

Copyright © 2005

by

Canadian Institute of Steel Construction

*All rights reserved. This book or any part thereof must
not be reproduced in any form without the written
permission of the publisher.*

First Edition

First Printing, September 2005

ISBN 0-88811-109-6

Cover Photo by Terri Meyer Boake

PRINTED IN CANADA

by

Quadratone Graphics Ltd.
Toronto, Ontario

Foreword

The Canadian Institute of Steel Construction is a national industry organization representing the structural steel, open-web steel joist and steel plate fabricating industries in Canada. Formed in 1930 and granted a Federal charter in 1942, the CISC functions as a nonprofit organization promoting the efficient and economic use of fabricated steel in construction.

As a member of the Canadian Steel Construction Council (CSCC), the Institute has a general interest in all uses of steel in construction. CISC works in close co-operation with the Steel Structures Education Foundation (SSEF) to develop educational courses and programmes related to the design and construction of steel structures. The CISC supports and actively participates in the work of the Standards Council of Canada, the Canadian Standards Association, the Canadian Commission on Building and Fire Codes and numerous other organizations, in Canada and other countries, involved in research work and the preparation of codes and standards.

Preparation of engineering plans is not a function of the CISC. The Institute does provide technical information through its professional engineering staff, through the preparation and dissemination of publications, through the medium of seminars, courses, meetings, video tapes, and computer programs. Architects, engineers and others interested in steel construction are encouraged to make use of CISC information services.

This guide has been prepared and published by the Canadian Institute of Steel Construction. It is an important part of a continuing effort to provide current, practical, information to assist educators, designers, fabricators, and others interested in the use of steel in construction.

Although no effort has been spared in an attempt to ensure that all data in this publication is factual and that the numerical values are accurate to a degree consistent with current structural design practice, the Canadian Institute of Steel Construction, the author and his employer, University of Alberta, do not assume responsibility for errors or oversights resulting from the use of the information contained herein. Anyone making use of the contents of this book assumes all liability arising from such use. All suggestions for improvement of this publication will receive full consideration for future printings.

CISC is located at

201 Consumers Road, Suite 300
Willowdale, Ontario, M2J 4G8

and may also be contacted via one or more of the following:

Telephone: (416) 491-4552
Fax: (416) 491-6461
Email: info@cisc-icca.ca
Website: www.cisc-icca.ca

Revisions

Future revisions to this publication will be posted on the CISC website: www.cisc-icca.ca. Users are encouraged to visit the CISC website periodically for updates.

Preface

In 2002, the author wrote a design guide for practicing engineers that was published by the American Institute of Steel Construction¹. To the maximum extent possible, the Guide was written in a generic style, but, inevitably, at many locations reference was made to the design rules provided by the AISC. The rules followed by Canadian engineers, those of the Canadian Standards Association, are sufficiently different from the AISC rules that the usefulness of the Guide was limited for them. The AISC was approached and they have graciously permitted the Canadian Institute of Steel Construction to publish a version of the Guide for those who design structures in Canada. The publisher and the author express their thanks to the AISC for their willingness to share the resource material.

The purpose of the publication is to provide engineers with an understanding of how high-strength bolts work in structures, how they are installed, and the requirements for inspection. These elements are not complicated, but it is the structural engineer who is responsible in one way or another for all these facets. The material presented brings all these features together and, after discussing the basics, links them to the requirements of CAN/CSA-S16-01 (buildings and related structures) or CAN/CSA-S6-00 (bridges).

It is necessary to say something about units. Canadian practice for a very long time has been to use the SI System of Units. However, the great majority of the research material behind the document was generated using Imperial units. Conversion of existing figures, graphs, and so on from one system to the other did not seem to be necessary and, moreover, could introduce errors. After considering the advantages and disadvantages, the author and the publisher decided to present figures and graphs in the original, Imperial, units. Since these are used mainly for descriptive purposes, this should not unduly inconvenience the user.

The author wishes to express his gratitude to the Canadian Institute of Steel Construction for their support of this project.

Geoffrey L. Kulak, Ph.D., P.Eng.

Edmonton, May 2005

¹ "High Strength Bolts: A Primer for Structural Engineers," Steel Design Guide 17, American Institute of Steel Construction, Chicago, IL, 2002.

TABLE OF CONTENTS

1. Introduction		
1.1 Purpose and Scope	1	
1.2 Historical Notes	1	
1.3 Mechanical Fasteners	1	
1.4 Types of Connections	4	
1.5 Design Philosophy	6	
1.6 Approach Taken in this Primer	7	
2. Static Strength of Rivets		
2.1 Introduction	9	
2.2 Rivets Subject to Tension	9	
2.3 Rivets in Shear	9	
2.4 Rivets in Combined Tension and Shear	10	
3. Installation of Bolts and Their Inspection		
3.1 Introduction	13	
3.2 Installation of High-Strength Bolts	13	
3.2.1 Turn-of-Nut Installation	14	
3.2.2 Calibrated Wrench Installation	17	
3.2.3 Pretensions Obtained using Turn-of-Nut Installation	17	
3.2.4 Tension-Control Bolts	17	
3.2.5 Use of Direct Tension Indicators	18	
3.3 Selection of Snug-Tightened or Pretensioned Bolts	19	
3.4 Inspection of Installation	20	
3.4.1 General	20	
3.4.2 Joints Using Snug-Tight Bolts	20	
3.4.3 Joints Using Pretensioned Bolts	20	
3.4.4 Arbitration	21	
4. Behavior of Individual Bolts		
4.1 Introduction	23	
4.2 Bolts in Tension	23	
4.3 Bolts in Shear	24	
4.4 Bolts in Combined Tension and Shear	25	
5. Bolts in Shear Splices		
5.1 Introduction	27	
5.2 Slip-Critical Joints	28	
5.3 Bearing-Type Joints	30	
5.3.1 Introduction	30	
5.3.2 Bolt Shear Capacity	30	
5.3.3 Bearing Capacity	30	
5.4 Tension and Shear Block	31	
5.5 Shear Lag	32	
6. Bolts in Tension		
6.1 Introduction	35	
6.2 Single Fasteners in Tension	35	
6.3 Bolt Force in Tension Connections	36	
7. Fatigue of Bolted and Riveted Joints		
7.1 Fundamentals	39	
7.2 Introduction to Fatigue of Bolted and Riveted Joints	39	
7.3 Riveted Joints	39	
7.4 Bolted Joints	41	
7.4.1 Bolted Shear Splices	41	
7.4.2 Bolts in Tension Joints	43	
8. Special Topics		
8.1 Introduction	45	
8.2 Use of Washers in Joints with Standard Holes	45	
8.3 Oversize or Slotted Holes	45	
8.4 Use of Long Bolts or Short Bolts	46	
8.5 Galvanized Bolts	47	
8.6 Reuse of High-Strength Bolts	47	
8.7 Joints with Combined Bolts and Welds	48	
8.8 Surface Coatings	48	
References	51	
Index		

Chapter 1

INTRODUCTION

1.1. Purpose and Scope

There are two principal types of fasteners used in contemporary fabricated steel structures—bolts and welds. Both are widely used, and sometimes both fastening types are used in the same connection. For many connections, it is common to use welds in the shop portion of the fabrication process and to use bolts in the field. Welding requires a significant amount of equipment, uses skilled operators, and its inspection is a relatively sophisticated procedure. On the other hand, bolts are a manufactured item, they are installed using simple equipment, and installation and inspection can be done by persons with only a relatively small amount of training.

Engineers who have the responsibility for structural design must be conversant with the behavior of both bolts and welds and must know how to design connections using these fastening elements. Design and specification of welds and their inspection methods generally involves selecting standardized techniques and acceptance criteria or soliciting the expertise of a specialist. On the other hand, design and specification of a bolted joint requires the structural engineer to select the type of fasteners, understand how they are to be used, and to set out acceptable methods of installation and inspection. Relatively speaking, then, a structural engineer must know more about high-strength bolts than about welds.

The purpose of this Primer is to provide the structural engineer with the information necessary to select suitable high-strength bolts, specify the methods of their installation and inspection, and to design connections that use this type of fastener. Bolts can be either common bolts (sometimes called ordinary or machine bolts) or high-strength bolts. Although both types will be described, emphasis will be placed on high-strength bolts. Because many riveted structures are still in use and often their adequacy must be verified, a short description of rivets is also provided.

1.2. Historical Notes

Rivets were the principal fastener used in the early days of iron and steel structures [1,2]. They were a satisfactory solution generally, but the clamping force produced as the heated rivet shrank against the gripped material was both variable and uncertain as to magnitude. Thus, use of rivets as the fastener in joints where slip was to be prevented was problematic. Rivets in connections loaded such that tension was produced in the fastener also

posed certain problems. Perhaps most important, however, the installation of rivets required more equipment and manpower than did the high-strength bolts that became available in a general way during the 1950's. This meant that it was more expensive to install a rivet than to install a high-strength bolt. Moreover, high-strength bolts offered certain advantages in strength and performance as compared with rivets.

Bolts made of mild steel had been used occasionally in the early days of steel and cast iron structures. The first suggestion that high-strength bolts could be used appears to have come from Batho and Bateman in a report made to the Steel Structures Committee of Scientific and Industrial Research of Great Britain [3] in 1934. Their finding was that bolts having a yield strength of at least 54 ksi could be pretensioned sufficiently to prevent slip of connected material. Other early research was done at the University of Illinois by Wilson and Thomas [4]. This study, directed toward the fatigue strength of riveted shear splices, showed that pretensioned high-strength bolted joints had a fatigue life at least as good as that of the riveted joints.

In 1947, the Research Council on Riveted and Bolted Structural Joints (RCRBSJ) was formed. This body was responsible for directing the research that ultimately led to the wide-spread acceptance of the high-strength bolt as the preferred mechanical fastener for fabricated structural steel. The Council continues today, and the organization is now known as the Research Council on Structural Connections (RCSC). The first specification for structural joints was issued by the RCRBSJ in 1951 [5].

At about the same time as this work was going on in North America, research studies and preparation of specifications started elsewhere, first in Germany and Britain, then in other European countries, in Japan, and elsewhere. Today, researchers in many countries of the world add to the knowledge base for structural joints made using high-strength bolts. Interested readers can find further information on these developments in References [6–10].

1.3. Mechanical Fasteners

The mechanical fasteners most often used in structural steelwork are rivets and bolts. On occasion, other types of mechanical fasteners are used: generally, these are special forms of high-strength bolts. Rivets and bolts are used in drilled, punched, or flame-cut holes to fasten the parts to

be connected. Pretension may be present in the fastener. Whether pretension is required is a reflection of the type and purpose of the connection.

Rivets are made of bar stock and are supplied with a preformed head on one end. The manufacturing process can be done either by cold or hot forming. Usually, a button-type head is provided, although flattened or countersunk heads can be supplied when clearance is a problem. In order to install the rivet, it is heated to a high temperature, placed in the hole, and then the other head is formed using a pneumatic hammer. The preformed head must be held in place with a backing tool during this operation. In the usual application, the second head is also a button head.

As the heated rivet cools, it shrinks against the gripped material. The result of this tensile strain in the rivet is a corresponding tensile force, the *pretension*. Since the initial temperature of the rivet and the initial compactness of the gripped material are both variable items, the amount of pretension in the rivet is also variable. Destructive inspection after a rivet has been driven shows that usually the rivet does not completely fill the barrel of the hole.

two different strength levels is shown in Fig. 1.1, along with those of bolt grades to be discussed later. (The plot shown in Fig. 1.1 represents the response of a coupon taken from the parent rivet or bolt.) Since the only reason for dealing with rivet strength today is in the evaluation of an existing structure, care must be taken to ascertain the grade of the rivets in the structure. Very old structures might have rivet steel of less strength than that reflected by ASTM A502. (This ASTM standard, A502, was discontinued in 1999.)

In fabricated structural steel applications, threaded elements are encountered as tension rods, anchor rods, and structural bolts. In light construction, tension members are often made of a single rod, threaded for a short distance at each end. A nut is used to effect the load transfer from the rod to the next component. The weakest part of the assembly is the threaded portion, and design is based on the so-called "stress area." The stress area is a defined area, somewhere between the cross-sectional area through the root of the threads and the cross-sectional area corresponding to the nominal bolt diameter.

Threaded rods are not a factory-produced item, as is the case for bolts. As such, a threaded rod can be made of

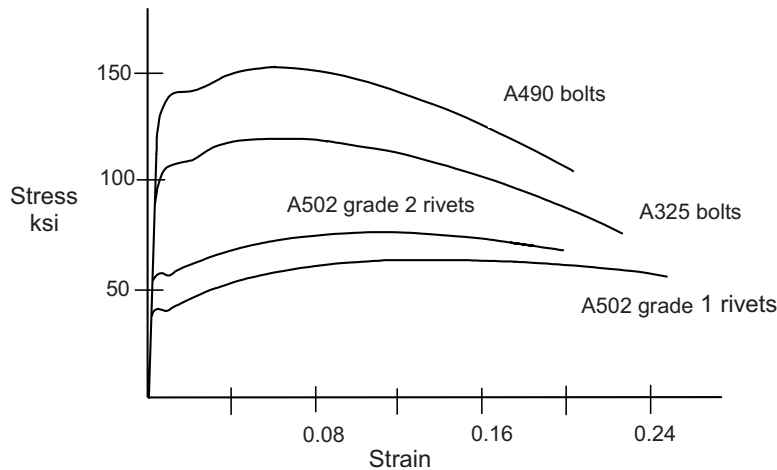

Fig. 1.1 Stress vs. Strain of Coupons taken from Bolts and Rivets

The riveting operation requires a crew of three or four and a considerable amount of equipment—for heating the rivets and for forming the heads—and it is a noisy operation.

The ASTM specification for structural rivets, A502, provided three grades, 1, 2, and 3 [11]. Grade 1 is a carbon steel rivet for general structural purposes, Grade 2 is for use with higher strength steels, and Grade 3 is similar to Grade 2 but has atmospheric corrosion resistant properties. The only mechanical property specified for rivets is hardness. The stress vs. strain relationship for the

any available steel grade suitable for the job.

Anchor rods are used to connect a column or beam base plate to the foundation. Like tension members, they are manufactured for the specific task at hand. If hooked or headed, only one end is threaded since the main portion of the anchor rod will be bonded or secured mechanically into the concrete of the foundation. Alternatively, anchor rods can be threaded at both ends and a nut used to develop the anchorage. Like threaded rods, anchor rods can be made of any grade of steel. One choice, however, is to use steel meeting ASTM A307,

which is a steel used for bolts, studs, and other products of circular cross-section.¹ It is discussed below.

Structural bolts are loosely classified as either *common* or *high-strength*.² Common bolts, also known as unfinished, ordinary, machine, or rough bolts, are covered by ASTM Specification A307 [12]. This specification includes the products known as *studs* and anchor bolts. (The term *stud* is intended to apply to a threaded product that will be used without a nut. It will be screwed directly into a component part.) Three grades are available in ASTM A307—A, B, and C. Grade B is designated for use in piping systems and will not be discussed here. Grade A has a minimum tensile strength of 60 ksi (415 MPa), and is intended for general applications. It is available in diameters from ¼ in. to 1½ in. Grade C is intended for structural anchorage purposes, i.e., non-headed anchor rods or studs. The diameter in this grade can be as large as 4 in. Structural

and the fact that the pretension (if needed for the type of joint) will be low and uncertain.

Two strength grades of high-strength steel bolts are used in fabricated structural steel construction. These are ASTM A325 [13] and ASTM A490 [14]. Structural bolts manufactured according to ASTM A325 can be supplied as Type 1 or Type 3 and are available in diameters from ½ in. to 1½ in. (Type 2 bolts did exist at one time but have been withdrawn from the current specification.) Type 1 bolts use medium carbon, carbon boron, or medium carbon alloy steel. Type 3 bolts are made of weathering steel and their usual application is in structures that are also of weathering steel. A325 bolts are intended for use in structural connections that are assembled in accordance with the requirements of the Research Council on Structural Connections Specification (RCSC) [15]. This link between the product specification (ASTM A325) and the use specification

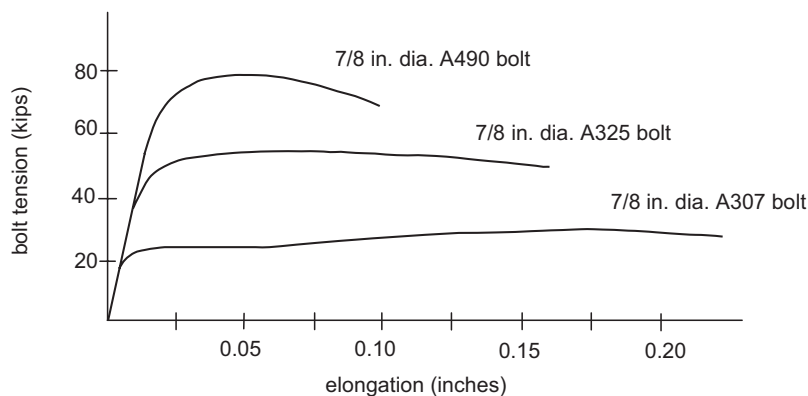

Fig. 1.2 Comparison of Bolt Types: Direct Tension

bolts meeting ASTM A307 are sometimes used in structural applications when the forces to be transferred are not particularly large and when the loads are not vibratory, repetitive, or subject to load reversal. These bolts are relatively inexpensive and are easily installed. The response of an ASTM A307 bolt in direct tension is shown in Fig. 1.2, where it is compared with the two types of high-strength bolts used in structural practice. The main disadvantages of A307 bolts are its inferior strength properties as compared with high-strength bolts

(RCSC) is explicitly stated in the ASTM A325 Specification. The minimum tensile strength of A325 bolts is 120 ksi (830 MPa) for diameters up to and including 1 in. and is 105 ksi (725 MPa) for diameters beyond that value.³

The other high-strength fastener for use in fabricated structural steel is that corresponding to ASTM A490. This fastener is a heat-treated steel bolt of 150 ksi (1030 MPa) minimum tensile strength (and maximum tensile strength of 170 ksi). As with the A325 bolt, it is intended that A490 bolts be used in structural joints that are made under the RCSC Specification. Two grades are available, Type 1 and Type 3. (As was the case with A325 bolts,

¹ ASTM F1554 –99 (Standard Specification for Anchor Bolts, Steel, 36, 55, and 105-ksi Yield Strength) is probably a more common choice today, however.

² Because bolts available in North America are generally in Imperial sizes, so-called "inch sizes" will generally be cited in this report. SI designated bolts are available, however.

³ The differentiation of strength with respect to diameter arose from metallurgical considerations. These metallurgical restrictions no longer exist, but the differentiation remains.

Type 2 A490 bolts were available in the past, but they are no longer manufactured.) Type 1, available in diameters of ½ to 1½ in., is made of alloy steel. Type 3 bolts are atmospheric corrosion resistant bolts and are intended for use in comparable atmospheric corrosion resistant steel components. They also can be supplied in diameters from ½ to 1½ in.

Both A325 and A490 bolts can be installed in such a way that a large pretension exists in the bolt. As will be seen, the presence of the pretension is a factor in some types of joints. This feature, and the concomitant requirements for installation and inspection, are discussed later.

There are a number of other structural fasteners covered by ASTM specifications, for example A193, A354, and A449. The first of these is a high-strength bolt for use at elevated temperatures. The A354 bolt has strength properties similar to that of the A490 bolt, especially in its Grade BD, but can be obtained in larger diameters (up to 4 in.) than the A490 bolt. The A449 bolt has strength properties similar to that of the A325 bolt, but it also can be furnished in larger diameters.⁴ It is often the specification used for high-strength anchor rods. Overall, however, A325, and A490 bolts are used in the

great majority of cases for joining structural steel elements.

The nuts that accompany the bolts (and washers, if required) are an integral part of the bolt assembly. Assuming that the appropriate mechanical fit between the bolt and the nut has been satisfied, the main attribute of the nut is that it have a strength consistent with that of the bolt. Principally, this means that the nut must be strong enough and have a thread engagement deep enough so that it can develop the strength of the bolt before the nut threads strip.⁵ For the structural engineer, the selection of a suitable nut for the intended bolt can be made with the assistance of ASTM A563, Standard Specification for Carbon and Alloy Steel Nuts [16]. A table showing nuts suitable for various grades of fasteners is provided in that Specification. Washers are described in ASTM F436 [17]. The RCSC Specification [15] provides summary information for both nut and washer selection.

1.4. Types of Connections

It is convenient to classify mechanically fastened joints according to the types of forces that are produced in the fasteners. These conditions are tension, shear, and

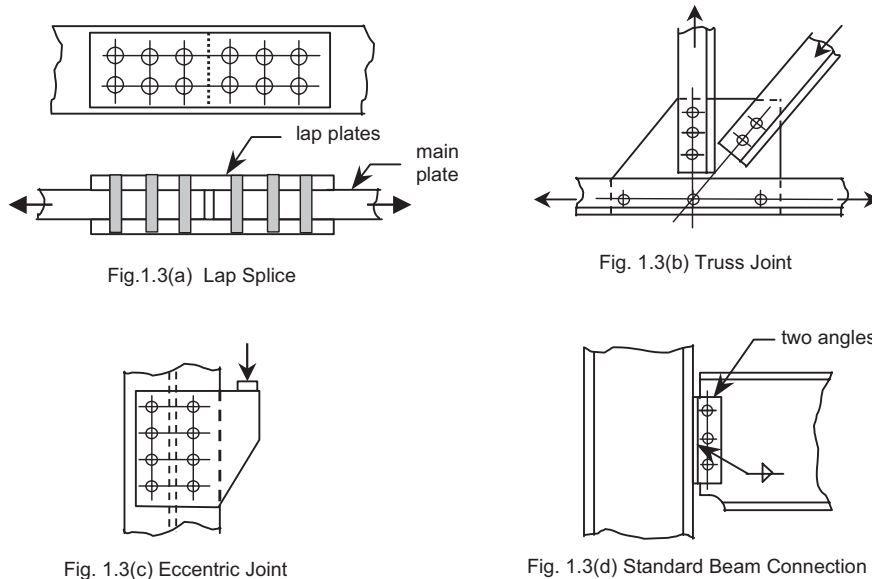

Fig. 1.3 Bolted Joint Configurations

⁴ Although the A354 and the A449 bolts have strength properties similar to the A325 and A490 bolts respectively, the thread length, quality assurance requirements, and packaging differ.

⁵ Strictly speaking, this is not always required. If the only function of the bolt is to transfer shear, then the nut only needs to keep the bolt physically in place. However, for simplicity, the nut requirement described is applied to all bolting applications.

combined tension and shear. In each case, the force can be induced in several different ways.

Figure 1.3 shows a number of different types of joints that will produce shear in the fasteners. Part (a) shows a *double lap* splice. The force in one main component, say the left-hand plate, must be transferred into the other main component, the right-hand plate. In the joint illustrated, this is done first by transferring the force in the left-hand main plate into the six bolts shown on the left-hand side of the splice. These bolts act in shear. Next, these six bolts transfer the load into the two splice plates. This transfer is accomplished by the bearing of the bolts against the sides of the holes in the plates.⁶ Now the load is in the splice plates, where it is resisted by a tensile force in the plate. Next, the load is transferred out of the splice plates by means of the six bolts shown on the right-hand side of the splice and into the main plate on the right-hand side. In any connection,

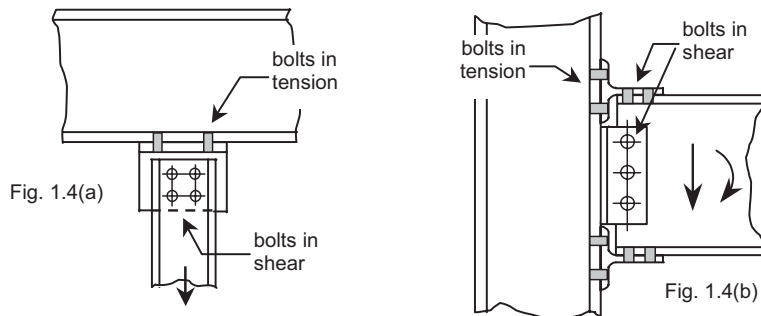

Fig. 1.4 Examples of Bolts in Tension

understanding the flow of forces is essential for proper design of the components, both the connected material and the fasteners. In the illustration, this visualization of the force flow (or, use of free-body diagrams!) allows the designer to see, among other things, that six fasteners must carry the total force at any given time, not twelve. More complicated arrangements of splice plates and use of different main components, say, rolled shapes instead of plates, are used in many practical applications. The problem for the designer remains the same, however—to understand the flow of forces through the joint.

Part (b) of Fig. 1.3 shows a panel point connection in a light truss. The forces pass out of (or into) the members and into (or out of) the gusset plate by means of the fasteners. These fasteners will be loaded in shear. Fig. 1.3 (c) shows a crane rail bracket. The fasteners again will be subjected to shear, this time by a force that

is eccentric relative to the center of gravity of the fastener group. The standard beam connection (Fig. 1.3 (d)) provides another illustration of fasteners that will be loaded in shear. There are numerous other joint configurations that will result in shear in the fasteners.

A joint in which tension will be induced in some of the fasteners is shown in Fig. 1.4 (a). This is the connection of a hanger to the lower flange of a beam. Figure 1.4 (b) shows a beam-to-column connection in which it is desired that both shear and moment be transmitted from the beam to the column. A satisfactory assumption for design is that all the shear force in the beam is in the web and all the beam moment is carried by the flanges. Accordingly, the fasteners in the pair of clip angles used to transfer the beam shear force are themselves loaded in shear. The beam moment (represented by a force couple located at the level of the flanges) is transmitted by the short tee sections that are

fastened to the beam flanges. The connection of the tee section to the beam flanges puts those fasteners into shear, but the connection of the top beam flange tee to the column flange puts those fasteners into tension.

Finally, one illustration is presented where both shear

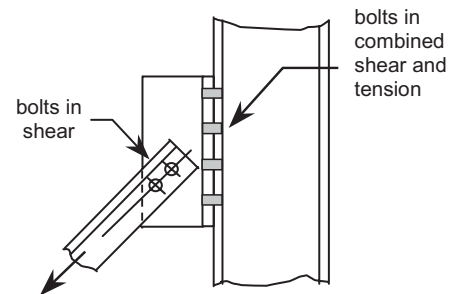

Fig. 1.5 Bolts in Combined Shear and Tension

and tension will be present in the fasteners. The inclined bracing member depicted in Fig. 1.5, shown as a pair of

⁶ Load transfer can also be by friction. This is discussed in Section 5.2.

angles, is a two-force member. Considering the tension case, resolution of the inclined tensile force into its horizontal and vertical components identifies that the fasteners that connect the tee to the column must resist the applied forces in both shear and in tension.

The example of load transfer that was demonstrated by Fig. 1.3 (a) can be taken one step further, as is necessary to establish the forces and corresponding stresses in the connected material. Figure 1.6 shows the same joint that was illustrated in Fig. 1.3 (a), except that it has been simplified to one bolt and two plates. Part (a) shows the joint. A free-body diagram obtained when the bolt is cut at the interface between the two plates is shown in Fig. 1.6 (b). (A short extension of the bolt is shown for convenience.) For equilibrium, the force in the plate, P , must be balanced by a force in the bolt, as shown. This is the shear force in the bolt. If necessary, it can be expressed in terms of the average shear stress, τ , in the bolt by dividing by the cross-sectional area of the bolt. Going one step further, the bolt segment is isolated in Fig. 1.6 (c). This free-body diagram shows that, in order to equilibrate the shear force in the bolt, an equal and opposite force is required. The only place this can exist is on the right-hand face of the bolt. This force is delivered to the bolt as the top plate pulls up against the bolt, i.e., the bolt and the plate bear against one another. Finally, the short portion of the top plate to the right of

the bolt, Fig. 1.6 (a), is shown in Fig. 1.6 (d). The force identified as a "bearing force" in Fig. 1.6 (c) must be present as an equal and opposite force on the plate in part (d) of the figure. This bearing force in the plate can be expressed as a stress, as shown, if that is more convenient. Finally, since the plate segment must be in equilibrium, the pair of forces, $P/2$, must be present in the plate.

These are simple illustrations of how some connections act and the forces that can be present in the bolts and in the adjacent connected material. There are some other cases in which the load transfer mechanism needs to be further explained, for example, when pretensioned high-strength bolts are used. This will be done in later chapters.

1.5. Design Philosophy

The process used in Canada to proportion fabricated steel structures is termed limit states design. In this approach, the performance of a structure is checked against various limiting conditions at appropriate load levels. The limiting conditions to be checked are ultimate limit states and serviceability limit states. Ultimate limit states are those states concerned with safety, for example, load-carrying capacity, overturning, sliding, and fracture due to fatigue or other causes. Serviceability limit states are those states in which the behaviour of the structure

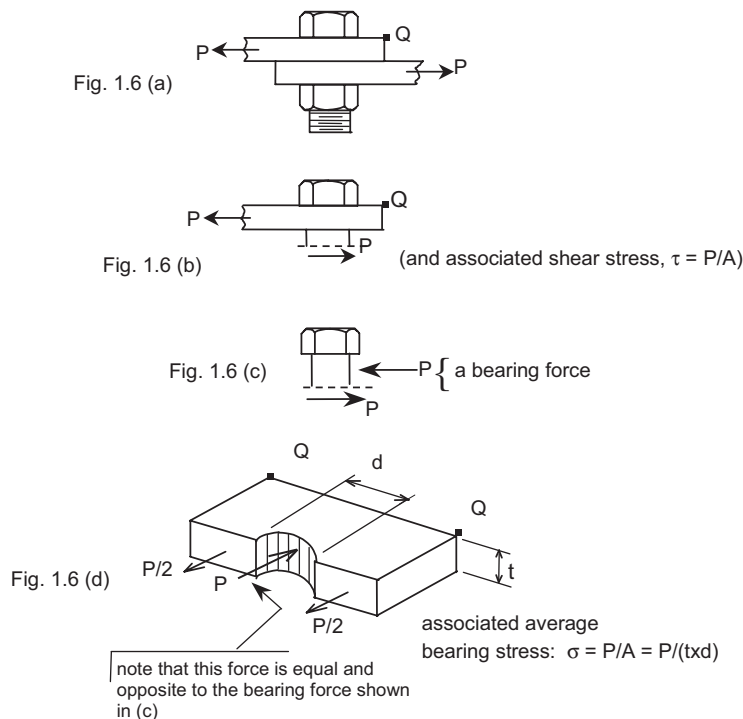

Fig.1.6 Bolt Forces and Bearing in Plate

under normal operating conditions is examined, and these include deflection, vibration, and permanent deformation.

In essence, the designer attempts to ensure that the maximum strength of a structure (or elements of a structure) is greater than the loads that will be imposed upon it, with a reasonable margin against failure. This is the ultimate limit state criterion. In addition, the designer must ensure that the structure will fulfill its function satisfactorily when subjected to its service loads. This is the serviceability limit state criterion.

The basic requirement for checking the ultimate limit state condition is that the factored resistance be equal to or greater than the effect of factored loads. In equation form, this can be written as

$$\phi R \geq \sum \alpha_i S_i \quad (1.1)$$

where

ϕ = resistance factor

R = nominal resistance of a structural element

α_i = load factor of i^{th} specified variable load

S_i = i^{th} specified variable load

S_i — For the National Building Code of Canada 2005, specified loads will consist of both principal loads and companion loads. A principal load is the specified variable load that dominates in a given load combination and the companion load is a specified variable load that accompanies the principal load in a given load combination. The magnitude of the load factor will depend on whether the specified variable load is a principal load or a companion load. Specified loads are dead load (D), live load (L), a variable load due to wind (W), a variable load due to snow (S), a rare load due to earthquake (E), a permanent load due to lateral earth pressure (H), permanent effects caused by prestress forces (P), and influences resulting from temperature changes, shrinkage, or creep of component materials, or from differential settlement (T). For loads due to snow, wind and earthquake, the value given must be also multiplied by an importance factor reflecting the importance of the structure, e.g., post-disaster requirements.

The material presented in this document is concerned almost exclusively with the left hand side of Equation 1.1. Here, the resistance factor, ϕ , is a factor applied to the nominal member strength, or resistance, to take into account the fact that the actual strength of a member may be less than anticipated because of variability of material properties, dimensions, and workmanship. In some limit states design formulations, the resistance factor also takes into account the type of failure anticipated for the member and uncertainty in prediction of member

resistance. In CAN/CSA-S16-01 [18], these are not in the resistance factor, ϕ , but have been included instead in the formulas that establish the theoretical member strengths (or member resistances). In general, ϕ is 0.90 for steel components and is 0.60 for concrete components. There are a number of exceptions, however, particularly in respect to the design rules for fasteners.

The *nominal* resistance, R, of a structural element is the strength calculated using the specified material properties, nominal dimensions, and equations describing the theoretical behaviour of the member, connection, or structure. Thus, in limit states terminology the *factored* resistance of a structural element, ϕR , is the product of the nominal resistance and the resistance factor. As expressed in Equation 1.1, the factored resistance must equal or exceed the effect of the factored loads (the right hand side of Equation 1.1).

In Equation 1.1, D, L, W, and T are the *specified* loads prescribed by the regulatory authority. Typical specified loads are listed in the National Building Code of Canada. The product of a specified load and the appropriate load factor is called a *factored* load. Factored loads must be used when checking ultimate limit states, but specified loads are used when checking serviceability limit states. More information on limit states design can be found in Reference [19].

One exception to this general rule occurs when designing structures for resistance to fatigue. Fatigue failure is considered to be an ultimate limit state, but the structure is designed to resist the effects of fatigue under the specified loads. This apparent anomaly exists because fatigue failure occurs as the result of a very large number of applications of the load normally expected to act on the structure (i.e., the specified load). Other ultimate limit state failures, such as the failure of a column, could occur due to a single application of a greater load than would normally be expected to act on the structure—in such a case the factored load is used in design calculations.

1.6. Approach Taken in this Primer

In this document, the usual approach is to describe the phenomenon under discussion in general terms, provide enough background information by way of research or, in some cases, theoretical findings, to enable a description of the phenomenon to be made, and then to provide a design rule. This is then linked to the corresponding rule in the specification for steel structures, i.e., CAN/CSA-S16 [18]. In a few cases, the reference specification will be CAN/CSA-S6-00, the Canadian Highway Bridge Design Code [20].

Chapter 2

STATIC STRENGTH of RIVETS

2.1 Introduction

As discussed in Chapter 1, rivets have not been used in the fabrication and erection of structural steel for many years. However, there are still reasons why a structural engineer may need to know about the behavior of rivets. Because they can be present in existing buildings and bridges, it follows that one objective is the necessity of evaluating the strength of these elements when a structure is considered for such things as renovation or the determination of safety under increased load levels. In this chapter, the static design strength of rivets is examined. The fatigue strength of a riveted connection, the other major area of interest, is more logically treated in Chapter 7, Fatigue of Bolted and Riveted Joints.

Rules for the design of rivets are not provided in either of the design sections for steel structures [18] or for bridges [20]. However, Section 14 of the latter (*Evaluation*) does give information on rivets and this is what will be used in this chapter. Clause 14.6.3.5 provides values to be used for the tensile strength of rivets if plans or mill certificates are not available. Clause 14.13.1.3 gives the design rules themselves.

2.2 Rivets Subject to Tension

The tensile stress vs. strain response for ASTM A502 rivet steel (i.e., undriven rivets) was shown in Fig. 1.1. The tensile strength is about 60 ksi (415 MPa) for Grade 1 and about 80 ksi (550 MPa) for Grade 2 or 3. After the rivet has been driven, the tensile strength can be significantly increased [21]. At the same time, however, the ductility of the driven rivet is considerably less than that of the material from which it was driven. Most tension tests of driven rivets also show a decrease in strength with increasing rivet length (grip). The residual clamping force that is present in a driven rivet does not affect the ultimate strength of the rivet. In principle then, the design tensile strength of a rivet is simply the product of the minimum tensile strength of the rivet material multiplied by a resistance factor.

Section 14 of the Canadian Highway Bridge Design Code [20] gives the factored tensile resistance of a riveted joint as

$$T_r = \phi_r n A_r F_u \quad (2.1)$$

where T_r = factored tensile resistance

ϕ_r = resistance factor

n = number of rivets

F_u = specified minimum tensile strength of the rivet steel

A_r = cross-sectional area of the rivet corresponding to its diameter.

The product $A_r F_u$ obviously is the ultimate tensile strength of the rivet shank. The value of the resistance factor ϕ_r recommended in the code is 0.67, which is relatively low, even for connection elements. There is no research available that identifies the appropriate value of the resistance factor for rivets in tension. However, the case of high-strength bolts in tension can be used as a basis of comparison. In Reference [22], it was established that $\phi = 0.85$ is a satisfactory choice for high-strength bolts in tension. This is also the value recommended in the *Guide* [6]. Thus, selection of the value 0.67 is a conservative choice for rivets. It results in values that are consistent with those used historically in allowable stress design and which also reflect the reality that a rivet may have deteriorated with time.

It is not uncommon for mechanical fasteners acting in tension to be loaded to a level that is greater than that corresponding to the total applied load divided by the number of fasteners. This is the result of prying action produced by deformation of the connected parts. It is advisable to follow the same rules for prying action in the case of rivets in tension as are recommended for bolts in tension. Prying action is discussed in Chapter 6.

The most common need for the strength calculation of a rivet or rivet group in tension will be to determine the strength of an existing connection. The integrity of the rivet heads should be closely examined. If the head is not capable of resisting the force identified in Eq. 2.1, then the calculation simply is not valid. Rivet heads in such structures as railroad bridges can be severely corroded as a result of the environmental conditions to which they have been subjected over the years.

2.3 Rivets in Shear

Numerous tests have been carried out to determine the shear strength of rivets—see, for example, References [21, 23, 24]. These tests all show that the relationship between the shearing force that acts on a rivet and its corresponding shearing displacement has little, if any, region that can be described as linear. Thus, the best description of the strength of a rivet in shear is its

ultimate shear capacity. In order to be able to compare rivets of different basic strengths, it is usual to relate the shear strength to the tensile strength of the steel from which the rivet is made. The results [21, 23] indicate that the value of this ratio (shear strength / tensile strength) is about 0.75. The ratio is not significantly affected by the grade of rivet or whether the shear test was done on driven or undriven rivets. However, there is a relatively wide spread in the value of the ratio, from about 0.67 to 0.83, according to the work in References [21 and 23].

Typical shear load vs. shear deformation tests are shown in Fig. 2.1 [25]. These tests are for 7/8 in. dia. A502 Grade 1 rivets with two different grip lengths, 3 in. and 4½ in. Because of greater bending in the longer rivets (and un-symmetrical loading in the case of these tests), there was greater deformation in these rivets in the early stages of the test. However, the ultimate shear strength was unaffected by grip length. Since driving of the rivet increases its tensile strength, the corresponding shear strength is likewise expected to increase.

The rivet tensile strengths depicted by the experiments shown in Fig. 1.1 are 60 ksi (415 MPa) for A502 Grade 1 and 80 ksi (550 MPa) for Grades 2 and 3. Using these values, the shear strength of Grade 1 A502 rivets can be expected to be at least $0.75 \times 415 \text{ MPa} = 310 \text{ MPa}$ and that for Grade 2 or Grade 3 rivets will be about $0.75 \times 550 \text{ MPa} = 415 \text{ MPa}$. (The multiplier 0.75 is not a resistance factor. It is the value of the ratio shear strength / tensile strength mentioned above.)

As was the case for rivets in tension, there have not been any studies that have explored the resistance factor for rivets in shear. The value recommended in the *Guide* [6] for bolts in shear is 0.80. In Reference [22], the resistance factor recommended is 0.83 for ASTM A325 bolts and 0.78 for ASTM A490 bolts.

The Canadian Highway Bridge Design Code [20] (Section 14) requires that the factored shear resistance of a riveted joint be taken as

$$V_r = 0.75 \phi_r n m A_r F_u \quad (2.2)$$

where ϕ_r = resistance factor, taken as 0.67

F_u = specified tensile strength of the rivet steel

A_r = cross-sectional area of a rivet

n = number of rivets

m = number of shear planes

As noted above, the product $0.75 F_u$ is the shear strength of a rivet. The other terms in Eq. 2.2 reflect the number of shear planes and the number of rivets.

Using Eq. 2.2 for the most common type of rivet steel, A502, presents a problem because that specification does not provide tensile strengths. Rather, hardness values are prescribed. The CAN/CSA-S6 [20] standard suggests (Clause 14.6.3.5) that the ultimate tensile

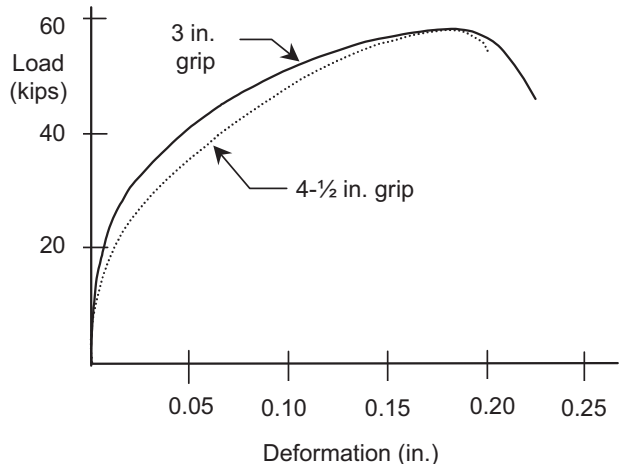

Fig. 2.1 Shear vs. Deformation Response of A502 Grade 1 Rivets

strength of A502 rivets be taken as 360 MPa unless better information is available. According to Eq. 2.2, the ultimate shear stress will then be taken as $0.75 \times 360 \text{ MPa} = 270 \text{ MPa}$. For a Grade 1 A502 rivet, the ultimate shear strength was described above as 310 MPa and for a Grade 2 or 3 rivet it was 415 MPa, according to test results. Thus, Eq. 2.2 is significantly conservative, even before the conservative feature of the resistance factor is taken into account. When evaluating the shear strength of rivets in an existing structure, these conservative elements of the design rule can be kept in mind.

The effect of joint length upon shear strength applied to bolted shear splices (Section 5.1.) should also be applied for long riveted connections.

2.4 Rivets in Combined Shear and Tension

It was explained in Section 1.4 (and with reference to Fig. 1.5) that fasteners must sometimes act under a combination of tension and shear. Tests done by Munse and Cox [23] form the basis for the design rule for this case. The tests were done on ASTM A141 rivets (which are comparable to A502 Grade 1 rivets), but the results are considered to be reasonable for application to all grades of rivets. The test variables included variation in grip length, rivet diameter, driving procedure, and manufacturing process. The only one of these variables that had an influence on the behavior was grip length: long grip rivets tended to show a decrease in strength with length. This is consistent with tests done on rivets loaded in shear only. As the loading condition changed from tension-only to shear-only, deformation capacity decreased. This also is consistent with observations for rivets in tension and rivets in shear.

An elliptical interaction curve was fitted to the test results [23]. The mathematical description of the curve is:

$$\frac{x^2}{(0.75)^2} + y^2 = 1.0 \quad (2.3)$$

where x = ratio of calculated shear stress (τ) to tensile strength of the rivet (σ_u), i.e., $x = \tau / \sigma_u$

y = ratio of calculated tensile stress (σ) to tensile strength of the rivet (σ_u), i.e., $y = \sigma / \sigma_u$

Using the symbols V_f and T_f for the factored shear force and factored tensile force, respectively, Eq. 2.3 can be written as

$$\frac{(V_f / A_r)^2}{0.56 F_u^2} + \frac{(T_f / A_r)^2}{F_u^2} = 1.0$$

where the number 0.56 has been written to replace 0.75^2 and the symbol F_u has replaced the symbol σ_u . After some algebraic manipulation this becomes–

$$V_f^2 + 0.56 T_f^2 = 0.56 (A_r F_u)^2$$

The only term that represents resistance is the right-hand side, and so this should now have a resistance factor associated with it. In addition, the equation will be written as a design requirement, i.e., as an inequality. Thus, it becomes

$$V_f^2 + 0.56 T_f^2 \leq 0.56 (\phi_r A_r F_u)^2 \quad (2.4)$$

and this is how the design requirement is written in Clause 14.13.1.3.3 of CAN/CSA S6, Chapter 14. The resistance factor, ϕ_r is to be taken as 0.67. Note that Eq. 2.3 and 2.4 are written for a single rivet.

Chapter 3

INSTALLATION OF BOLTS AND THEIR INSPECTION

3.1 Introduction

The installation of bolts, both high-strength bolts and common bolts, is presented in this chapter. This is accompanied by information on the inspection process that is necessary to ensure that the expectations of the installation have been met. Further information on the physical characteristics and mechanical properties of bolts is also included.

High-strength bolts can be installed in a way such that an initial pretension (or, preload) is present. The installation of ordinary bolts (i.e., ASTM A307) does not result in any significant pretension. For some applications, the presence of a pretension affects how the joint performs, and the inspection of installation of high-strength bolts should reflect whether or not bolt pretension is required. Whether bolts should be pretensioned is important in both the installation and inspection processes. Because of this importance, advice is given as to when pretensioned bolts should be required.

3.2 Installation of High-Strength Bolts

A bolt is a headed externally threaded fastener, and it is intended to be used with a nut. High-strength bolts were introduced in Section 1.3, and for structural applications two types of bolts are used—ASTM A325 and ASTM A490. Washers may or may not be required (see Chapter 8), depending on the application. Both the bolt head and the nut are hexagonal. The shank is only partially threaded, and the threaded length depends on the bolt diameter. Complete information on these details can be obtained in the relevant specifications [13, 14].

Not all structural bolts used in practice precisely meet the definition just given. Two other bolt configurations are in common use. These are bolts that meet or replicate the ASTM A325 or A490 requirements, but which have special features that relate to their installation. One is the "twist-off" bolt, which is covered by ASTM Specification F1852. It is described in Section 3.2.4. The other case is different from the conventional bolt–nut set only by the addition of a special washer that acts as an indicator of the pretension in the bolt. Its installation and other characteristics are described in Section 3.2.5.

Bolts meeting the requirements of ASTM Standards A325 and A490 were first described in Section 1.3. It was noted there that the ultimate tensile strength level for A325 bolts is 120 ksi (830 MPa) or 105 ksi (725 MPa). The former applies to bolts of diameter up to and including 1 in. and the latter for bolts greater than 1 in. diameter. There is no maximum ultimate tensile strength

specified for A325 bolts. The other kind of high-strength bolt used in structural practice, ASTM A490, has a specified ultimate tensile strength of 150 ksi (1030 MPa) and a maximum tensile strength of 173 ksi (1190 MPa) for all diameters. In each case, the mechanical requirements of the specifications also make reference to a so-called proof load. This is the level up to which the bolt can be loaded and then unloaded without permanent residual deformation. In mild structural steels, this is termed the yield strength. However, in the case of the high-strength bolts there is no well-defined yield strength and all the design strength statements for high-strength bolts use the ultimate tensile strength as the basic parameter. Hence, the designer need not be concerned about the proof load.

It is required that the nuts for high-strength bolts used in normal structural applications are heavy hex nuts that conform to the requirements of ASTM Standard A563 [16]. (If the bolts are to be used in high-temperature or high-pressure applications, then another ASTM Standard is used for identifying the appropriate nuts.) When zinc-coated A325 bolts are to be used, then the nuts must also be galvanized and tapped oversize. In this case, requirements for lubrication of the nuts and a rotation capacity test for the bolt–nut assembly are specified in ASTM Standard A325. (This is discussed in Section 8.5.)

Bolts are installed by first placing them in their holes and then running the nut down on the bolt thread until it contacts the connected plies. This can be done either manually, by using a spud wrench,⁷ or using a power tool, which is usually a pneumatic impact wrench⁸. The expectation is that the connected parts will be in close contact, although in large joints involving thick material it cannot be expected that contact is necessarily attained completely throughout the joint. The installation process should start at the stiffest part of the joint and then progress systematically. Some repetition may be required. The condition of the bolts at this time is referred to as *snug-tight*, and it is attained by the full effort of the ironworker using a spud wrench or by running the nut down until the air-operated wrench first starts to impact. The bolt will undergo some elongation during this

⁷ A spud wrench is the tool used by an ironworker to install a bolt. It has an open hexagonal head and a tapered handle that allows the worker to insert it into holes for purposes of initial alignment of parts.

⁸ Electric wrenches are also available and are particularly useful for smaller diameter bolts.

process, and there will be a resultant tensile force developed in the bolt. In order to maintain equilibrium, an equal and opposite compressive force is developed in the connected material. The amount of the bolt tension at the snug-tightened condition is generally large enough to hold the parts compactly together and to prevent the nut from backing off under static loads. As an example, in laboratory tests snug-tight bolt pretensions range from about 5 to 10 kips (22 to 44 kN) for 7/8 in. diameter A325 bolts. In practice, the range is probably even larger.

For many applications, the condition of snug-tight is all that is required. Because use of snug-tightened bolts is an economical solution, they should be specified whenever possible. If the function of the joint requires that the bolts be pretensioned, then bolt installation must be carried out in one of the ways described following. Whether or not the bolts need to be pretensioned is described in Section 3.3.

3.2.1 Turn-of-Nut Installation

If the nut continues to be turned past the location described as snug-tight, then the bolt tension will continue to increase. In this section, the installation process described is that in which a prescribed amount of turn of the nut is applied. This is an elongation method of controlling bolt tension, and it is the only generic method of installation permitted by S16. However, S16 does permit the use of load-indicating washers or the use of twist-off bolts. These are discussed later in the chapter.

As the nut is turned, conditions throughout the bolt are initially elastic, but local yielding in the threaded portion soon begins. Most of the yielding takes place in the region between the bolt thread run-out and the first few loaded threads of the nut. As the bolt continues to elongate under the action of turning the nut, the bolt load

(pretension) vs. elongation response flattens out, that is, the bolt pretension force levels off.

Figure 3.1 shows the bolt pretension obtained by turning the nut on a certain lot of A325 bolts [26]. These were 7/8 in. diameter bolts that used a grip length of 4–1/8 in. (In this laboratory study, the snug-tight condition was uniquely established for all bolts in the lot by setting the snug-tight load at 8 kips.) It can be seen that the average response is linear up to a load level slightly exceeding the specified proof load, then yielding starts to occur in the threads and the response curve flattens out. Also shown in the figure is the range of elongations that were observed at 1/2 turn past snug, which is the RCSC Specification requirement [15] for bolts of the length used in this study. The specified minimum bolt pretension is 39 kips (174 kN) for A325 bolts of this diameter, and it can be observed that the measured pretension at 1/2 turn is well above this value. (The minimum bolt pretension required is 70% of the specified minimum ultimate tensile strength of the bolt [15].)

Figure 3.1 also shows that the specified minimum tensile strength of the bolt (i.e., direct tension) is well above the maximum bolt tension reached in the test (i.e., torqued tension). This reflects the fact that during installation the bolts are acting under a condition of combined stresses, tension and torsion.

The results of the bolt installation shown in Fig. 3.1, which is typical of turn-of-nut installations, raise the following questions:

- How do such bolts act in joints, rather than individually as depicted in Fig. 3.1?
- If the bolts subsequently must act in tension, can they attain the specified minimum tensile strength?
- Does the yielding that takes place in the bolt threads (mainly) affect the subsequent strength of the bolt in shear, tension, or combined tension and shear?
- What is the margin against twist-off of the bolts in the event that more than 1/2 turn is applied inadvertently?
- How sensitive is the final condition (e.g., bolt pretension at 1/2 turn) to the level of the initial pretension at snug-tight?

The first three items in the list apply to bolts installed by any procedure: the others are specific to turn-of-nut installations.

Several of these questions can be addressed by looking at the behavior of bolts that were taken from the same lot as used to obtain Fig. 3.1 when they were installed in a large joint [6]. Figure 3.2 shows the bolt

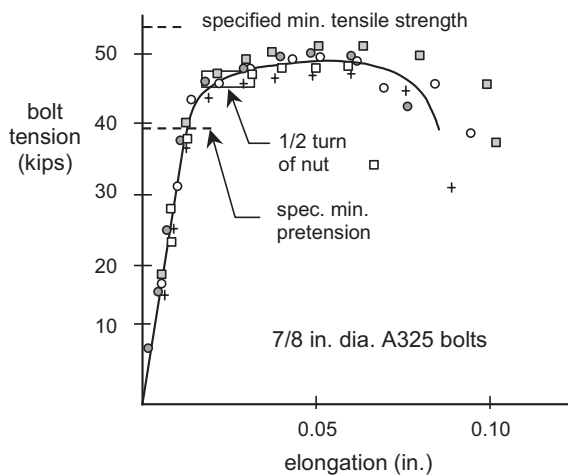

Fig. 3.1 Load vs. Elongation Relationship, Torqued Tension

elongations and subsequent installed pretensions for 28 of these bolts installed to 1/2 turn of nut beyond snug-tight.

The individual bolt pretensions can be estimated by projecting upward from the bolt elongation histogram at the bottom of the figure to the plot of bolt pretensions obtained by the turn-of-nut installation. Even though there is a large variation in bolt elongation for these 28 bolts (from about 0.03 in. to nearly 0.05 in.), the resultant pretension hardly varies at all. This is because the bolts have entered the inelastic range of their response. Thus, the turn-of-nut installation results in a reliable level of bolt pretension and one that is consistently above the minimum required bolt pretension.

The second thing that can be observed from Fig. 3.2 is that, even though the range of bolt pretension at the snug condition was large (from about 16 kips to 36 kips), the final pretension is not affected in any significant way. Again, this is because the bolt elongation imposed during the installation procedure has taken the fastener into the inelastic region of its behavior.

It is highly unlikely that a high-strength bolt, once installed, will be turned further than the prescribed installation turn. Because of the extremely high level of bolt pretension present, about 49 kips in the example of Fig. 3.2, it would require considerable equipment to overcome the torsional resistance present and further turn the nut. In other words, it would require a deliberate act to turn the nut further, and this is not likely to take place in either bridges or buildings once construction has been completed. It is possible, however, that an ironworker could inadvertently apply more than the prescribed turn. For instance, what is the consequence if a nut has been turned to, say, 1 turn rather than to 1/2 turn?

The answer to this question is twofold. First, at 1 turn of the nut the level of pretension in the bolt will still be above the specified minimum pretension [6]. In fact, the research shows that the pretension is likely to still be high just prior to twist-off of the fastener. Second, the margin against twist-off is large. Figure 3.3 shows how bolt pretension varies with the number of turns of the nut for two lots of bolts, A325 and A490, that were 7/8 in. diameter and 5-1/2 in. long and had 1/8 in. of thread in the grip [6]. The installation condition for this bolt length is 1/2 turn past snug. It can be seen that it was not until about 1-3/4 turns that the A325 bolts failed and about 1-1/4 turns when the A490 bolts failed. In other words, there is a considerable margin against twist-off for both fastener types.

It was observed in discussing the data in Fig. 3.1 that the pretension attained by the process of turning a nut onto a bolt does not reach the maximum load that can be attained in a direct tension test of the bolt. The presence of both tensile stresses and torsional stresses in the former case degrades the strength. However, laboratory tests for both A325 and A490 bolts [26, 27] show that a bolt installed by the turn-of-nut method and then subsequently loaded in direct tension only is able to attain its full direct tensile strength. This is because the torsional stresses introduced in the installation process are dissipated as the connected parts are loaded and the contact stresses decrease. Thus, bolts installed by turning on the nut against gripped material can be proportioned for subsequent direct tension loading on the basis of their ultimate tensile strength.

The strength of bolts in shear is likewise unaffected by the stresses imposed during installation. This is

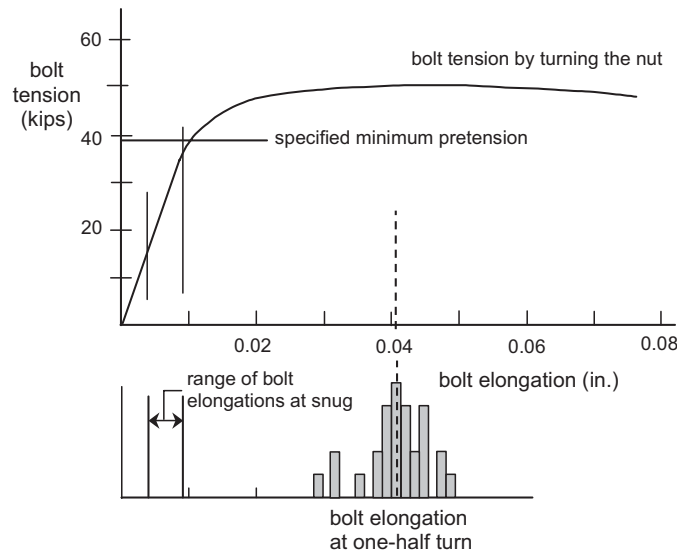

Fig. 3.2 Bolt Tension in Joint at Snug and at One-Half Turn of Nut

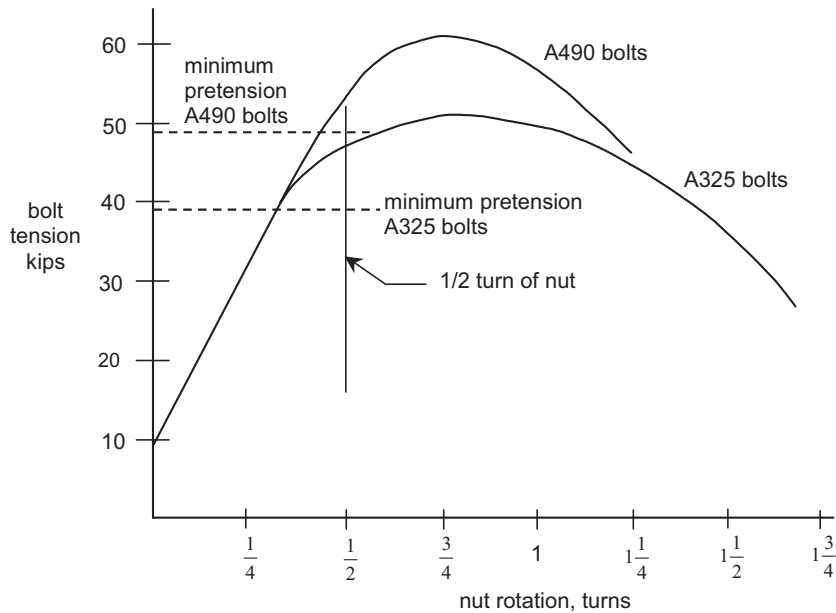

Fig. 3.3 Bolt Load vs. Nut Rotation

elaborated upon in the discussion in Section 4.3, where the strength of bolts in shear is described.

It will be seen in Section 4.4 that the design rule for the capacity of bolts in combined tension and shear is an interaction equation developed directly from test results. Hence, the question as to how the strength might be affected is not influenced by the pre-existing stress conditions. In any event, since neither the direct tensile strength nor the shear strength is affected by pretension, it is unlikely that the combined tension and shear case is influenced.

The discussion so far has described bolts that are installed to 1/2 turn past snug. In practice, this will indeed be the requirement applicable in a great many practical cases. However, for longer bolts, 1/2 turn may not be sufficient to bring the pretension up to the desired level, whereas for shorter bolts 1/2 turn might twist off the bolt. Laboratory studies show that for bolts whose length is over eight diameters but not exceeding 12 diameters, 2/3 turn of the nut is required for a satisfactory installation. For short bolts, those whose length is up to and including four diameters, 1/3 turn of nut should be applied. The bolt length is taken as the distance from the underside of the bolt head to the extremity of the bolt. It is expected that the end of the bolt will either be flush with the outer face of the nut or project slightly beyond it. If the combination of bolt length and grip is such that there is a large "stick-through," then it is advisable to treat the bolt length as the distance from the underside of the bolt head to the outer face of the nut for the purpose of selecting the proper turn to be applied.

These rules apply when the outer faces of the bolted parts are normal to the axis of the bolts. Certain structural

steel shapes have sloped surfaces—a slope up to 1:20 is permitted. When non-parallel surfaces are present, the amount of turn-of-nut differs from those cases just described. The exact amount to be applied depends upon whether one or both surfaces are sloped. The RCSC Specification should be consulted for these details. Alternatively, beveled washers can be used to adjust the surfaces to within a 1:20 slope, in which case the resultant surfaces are considered parallel.

It is important to appreciate that the connected material within the bolt grip must be entirely steel. If material more compressible than steel is present, for example if material for a thermal break were contemplated, then the turn-of-nut relationships developed for solid steel do not apply. Whatever the bolt type and method of installation, the problems that can arise have to do with the attainment and retention of bolt pretension. The RCSC Specification simply takes the position that all connected material must be steel.

Users of bolts longer than about 12 bolt diameters should exercise caution: bolts of these lengths have not been subjected to very much laboratory investigation for turn-of-nut installation. The installation of such bolts should be preceded by calibration tests to establish the appropriate amount of turn of the nut.

Generally speaking, washers are not required for turn-of-nut installations that use A325 bolts. The main exceptions are (a) when non-parallel surfaces are present, as discussed above and (b) when slotted or oversized holes are present in outer plies. As discussed in Section 8.2, washers are required for some turn-of-nut installations that use A490 bolts. The use of slotted or oversized holes is discussed in Section 8.3. The necessity for washers

when A490 bolts are used arises because galling and indentation can occur as a result of the very high pretensions that will be attained with these bolts. If galling and indentation take place under the bolt head or nut, the resultant pretension can be less than expected. Use of hardened washers under both the bolt head and the nut will eliminate this problem. However, most steels in use today can be successfully joined using A490 bolts without washers. Further details are found in Chapter 8.

It should also be observed that any method of pretensioned installation, of which turn-of-nut is the only one discussed so far, can produce bolt pretensions greater than the specified minimum value. This is not a matter for concern. Those responsible for the installation of high-strength bolts and inspectors of the work should understand that attainment of the "exact" specified value of pretension is not the goal and that exceeding the specified value is acceptable.

3.2.2 Calibrated Wrench Installation

Theoretical analysis identifies that there is a relationship between the torque applied to a fastener and the resultant pretension [28]. It is therefore tempting to think that bolts can successfully be installed to specified pretensions by application of known amounts of torque. The relationship between pretension and torque is a complicated one, however, and it reflects such factors as the thread pitch, thread angle and other geometrical features of the bolt and nut, and the friction conditions between the various components of the assembly. As a consequence, it is generally agreed that derived torque vs. pretension relationships are unreliable [6, 28]. The RCSC Specification [15] is explicit upon this point. It states that, "This Specification does not recognize standard torques determined from tables or from formulas that are assumed to relate torque to tension."

A torque-based installation method is possible provided that the installation wrench is calibrated. This would have to be done using a representative sample of the bolts to be installed. At one time, the S16 Specification did allow this, but it has not been permitted for many years. The turn-of-nut method of installation is simpler, provides consistent levels of bolt preload, and leads to fewer disputes in the field. A form of torque-based installation, the use of tension-control bolts, is discussed in Section 3.2.4.

3.2.3 Pretensions Obtained using Turn-of-Nut Installation

The installation method described in Section 3.2.1 is for those situations where bolt pretension is required in order that the joint fulfill the intended purpose. (See Section 3.3.) Accordingly, it is appropriate to comment on the bolt pretensions actually obtained, as compared to the

specified minimum values. As already mentioned, the specified minimum bolt pretension corresponds to 70% of the specified ultimate tensile strength. (These are the pretension values listed in Table 7 of S16-01.)

Laboratory studies show that the actual bolt pretension obtained when turn-of-nut installation is used can be substantially greater than the value specified. This increase is the result of two factors. One is that production bolts have an actual tensile strength that is appreciably greater than the specified minimum value. The other factor is that turn-of-nut installation produces pretensions greater than the specified value regardless of the bolt strength. For example, in the case of A325 bolts, production bolts are about 18% stronger than their specified minimum tensile strength and turn-of-nut (1/2 turn) produces a pretension that is about 80% of the actual tensile strength [6]. It follows then that the installed bolt pretension will be about $(1.18 \times 0.80 =) 0.95$ times the specified minimum tensile strength of A325 bolts. In other words, the average actual bolt pretension is likely to exceed the required minimum value by about $[(0.95 - 0.70) / 0.70] 100\% = 35\%$ when turn-of-nut is used. A similar examination of A490 bolts installed in laboratory conditions shows that the average bolt pretension can be expected to exceed the minimum required bolt pretension by approximately 26% [6]. Field studies are available that support these conclusions [29].

It is shown in Section 5.2 that these observed bolt tension values are a component of the design rules for slip-critical connections.

In summary, the use of the turn-of-nut method of installation is reliable and produces bolt pretensions that are consistently above the prescribed values.

3.2.4 Tension-Control Bolts

Tension-control bolts, ASTM F1852, are fasteners that meet the overall requirements of ASTM A325 bolts, but which have special features that pertain to their installation [30]. In particular, the bolt has a splined end that extends beyond the threaded portion of the bolt and an annular groove between the threaded portion of the bolt and the splined end. Figure 3.4 shows an example of



Fig. 3.4 Tension-Control Bolt

a tension-control bolt. The bolt shown has a round head (also called button or, dome, head), but it can also be supplied with the same head as heavy hex structural bolts. The bolt, nut, and washer must be supplied as an assembly, or, "set."

The special wrench required to install these bolts has two coaxial chucks—an inner chuck that engages the splined end and an outer chuck that envelopes the nut. The two chucks turn opposite to one another to tighten the bolt. At some point, the torque developed by the friction between the nut and bolt threads and at the nut–washer interface overcomes the torsional shear resistance of the bolt material at the annular groove. The splined end of the bolt then shears off at the groove. If the system has been properly manufactured and calibrated, the target bolt pretension is achieved at this point. Factors that control the pretension are bolt material strength, thread conditions, the diameter of the annular groove, and the surface conditions at the nut–washer interface. The installation process requires just one person and takes place from one side of the joint only, which is often an economic benefit. The wrench used for the installation is electrically powered, and this can be advantageous in the field.

Research that investigated the pretension of production tension-control bolts as it varied from manufacturer to manufacturer and under different conditions of aging, weathering, and thread conditions is available [31]. The results show that the pretension in a tension control bolt is a strong reflection of the friction conditions that exist on the bolt threads, on the bearing face of the nut, and on the washers supplied with the bolts. In this study, the quality of the lubricant supplied by the manufacturer varied, and in many cases the effectiveness of the lubricant decreased with exposure to humidity and the elements.

The installation of a tension-control bolt uses a method that depends on torque. As such, the process must undergo a pre-installation procedure that will ensure that the installation process will produce adequate levels of bolt pretension. This process is laid out in Clause 23.8.4 of S16–01 [18]. At least three complete bolt assemblies that are representative of the bolt diameter, length, grade, and lot to be used must be tested in a device capable of indicating the tension in the bolt as the torque is applied. The load-indicating device used is generally a hydraulic load cell (one trade name, Skidmore–Wilhelm). The target value of pretension is 5% greater than the specified minimum value given in the Specification. The 5% increase is intended to provide a margin of confidence between the sample size tested and the actual installation of bolts in the work. Washers must be used with F1852 bolts in order that friction conditions at the nut–washer interface are controlled.

The calibration process must be carried out at the start of the job or at any time that the variables change, i.e., changes in bolt diameter or length, grade, or manufacturing lot. Particular attention should be paid to proper storage and handling of tension-control bolts and to any possible deterioration of the as-delivered lubrication with time. In such cases, a new pre-installation calibration must be carried out.

Although there are laboratory studies of installed pretensions in joints made with twist-off bolts, there are no field studies. In many respects they are similar to bolts installed by calibrated wrenches, which is permitted under U.S. specifications. Laboratory studies are available for this case, and it is found that the minimum required pretension is likely to be exceeded by about 13% [6]. Note that this is significantly less than the pretension obtained when the turn-of-nut installation method is used.

3.2.5 Use of Direct Tension Indicators

Installation of high-strength bolts to target values of bolt pretension can also be carried out using direct tension indicators [32]. These are washer-type elements, as defined in ASTM F959 and shown in Fig. 3.5, that are placed under the bolt head or under the nut. As the nut is turned, small arch-shaped protrusions that have been formed into the washer surface compress in response to the pretension that develops in the bolt. If a suitable calibration has been carried out, the amount of pretension in the bolt can be established by measuring the size of the gap remaining as the protrusions close. This calibration requires that a number of individual measurements be made in a load-indicating device and using a feeler gauge to measure the gap.⁹ For example, there are five protrusions in the direct tension indicating washer used with a 7/8 in. dia. A325 bolt. There must be at least three feeler gage refusals at the target value of the gap, which is 0.015 in. Details of the direct tension indicating washer itself and the procedure necessary for calibration are



Fig. 3.5 Direct Tension Indicator

⁹ In practice, measurements are not performed, but a verifying feeler gage is used.

given in the RCSC Specification [15] and in the ASTM Standard [32]. Over and above the particularities of the direct tension indicating washer itself, the verification process is similar to that for calibrated wrench installation.

The use of the load-indicating washer to install high-strength steel bolts is a deformation method of control, and so it is not subject to the friction-related variables that are associated with the calibrated wrench and tension-control bolt methods. As is the case for the tension-control bolts, there are not many field studies of the effectiveness of direct tension indicators. The results that are available seem to be mixed. In one report [29] the ratio of measured pretension to specified minimum tension was 1.12 for a sample of 60 A325 bolts that used direct tension indicating washers. Although this is not as high as found in turn-of-nut installations, it is a satisfactory result. Other studies [33, 34], which encompassed only A490 bolts, indicate that specified minimum bolt tensions may not be reached at all when direct tension indicators are used to install large diameter, relatively long bolts. Some, but not all, of the difficulties reported relate to the bolt length and fastener grade, *per se*, rather than the use of the direct tension indicator. However, if the direct tension indicators are used in accordance with the requirements given in the RCSC Specification the bolt pretensions that are produced can be expected to be satisfactory.

3.3 Selection of Snug-Tightened or Pretensioned Bolts

Two of the three design specifications referenced in this document (RCSC and S16–01) require that the designer identify whether the bolts used must be pretensioned or need only be snug-tightened. The design documents must indicate the intention of the designer. In this way, the plan of the designer when the joint was proportioned will be fulfilled by those responsible for the shop fabrication, field erection, and inspection of the work. The other specification cited, S6–00, simply requires that all joints be designed as slip-critical, meaning that all bolts must be pretensioned.

Bridges—An important aspect of the design of bridges is the fact that moving loads are present and that they are repetitive. If the connections were to slip under the action of these loads, undesirable structural behavior could result (e.g., fatigue cracking), and unacceptable changes in geometry might take place. Accordingly, the Highway Bridge Design Code [20] requires that all joints be designed as *slip-critical* and, this, in turn, means that all bolts must be pretensioned.

Buildings—The requirements for buildings allow latitude in the selection of the bolt installation condition. It is not usual for a building to have moving loads, and wind and earthquake forces are not considered to result in fatigue. Consequently, the need for pretensioned and slip-

critical bolts is not as frequent in buildings as it is for bridges.

There are three conditions for bolted connections that can be used in buildings. For economy and proper function, it is important that the correct one be specified.

The S16–01 Standard enumerates the cases where it is necessary that the bolts be installed to a specified minimum pretension in Clause 22.2.2. These include connections that have cyclic or impact loading, connections that use oversize or slotted holes, seismically loaded joints, and joints where the bolts are subject to tensile loading. Only the latter case is counter-intuitive because the ultimate strength of such bolts is independent of the pretension (Chapter 4). It is considered good practice that the parts of a joint loaded in tension not separate under the service loads, hence the requirement that these bolts be pretensioned.

- **Connections using Snug-Tightened Bolts**—Neither the shear strength of a high-strength bolt nor the bearing capacity of the connected material are affected by the level of bolt pretension. Likewise, the tensile capacity is unaffected by bolt pretension, unless loads that might cause fatigue are present. (These items are discussed in Chapters 4 and 5.) Hence, the majority of bolted connections in buildings need only use snug-tightened bolts, i.e., the bolts are installed using the full effort of an ironworker with a spud wrench. This is the most economical way of making bolted connections in buildings because no compressed air or attendant equipment is needed, washers may not be required, and inspection is simple.

The consequence of the S16 requirements is that in most buildings, only the joints in bracing members and joints where tension is induced in the bolts by the loading need to have pretensioned bolts. In the case of the former, the connection should be slip-critical as well.

- **Connections using Pretensioned Bolts**—In building connections where the joint must use pretensioned bolts but are not slip-critical, i.e., joints that are loaded such that the bolts are in tension, the surface condition of the connected material is not relevant. It is simply required that the bolts be installed to their prescribed pretension.

It is obvious that the bolt installation costs and inspection for joints requiring pretensioned bolts will be higher than if the bolts need only be snug-tightened.

- **Slip-Critical Connections**—As already described, this type of connection is required for all joints in bridges, where fatigue is a consideration, and is required in buildings for certain cases, especially

bracing members. In buildings, wind is not considered to be a fatigue phenomena. However, if oversized holes or slotted holes that run parallel to the direction of the member forces are used, slip-critical connections are required in buildings. This is generally interpreted to include the joints in lateral bracing systems. It is important to note also that connections that must resist seismic forces need to receive special attention.

If slip-critical connections are used unnecessarily in buildings, higher installation and inspection costs will result.

The requirements relative to snug-tight, pretensioned, or slip-critical joints are somewhat different in the RCSC Specification, but essentially cover the same ground as explained here for the S16 Standard.

3.4 Inspection of Installation

3.4.1 General

Inspection of the installation of any fabricated steel component is important for several reasons. It is self-evident that the integrity of the component must be assured by the inspection process. At the same time, the inspection must be done at a level that is consistent with the function of the element under examination and an understanding of its behavior. For example, if the inspection agency thinks (incorrectly) that bolt pretensions are subject to a maximum value as well as a minimum value, this will lead to a dispute with the steel erector and an unnecessary economic burden. In sum, then, the level of inspection must be consistent with the need to examine the suitability of the component to fulfill its intended function, but it must not be excessive in order that the economical construction of the job is not affected.

In the case of high-strength bolts, the first step must be an understanding of the function of the fastener in the joint. If bolt pretension is not required, then the inspection process should not include examination for this feature. This seems self-evident, but experience has proven that inspection for bolt pretension still goes on in cases where bolt pretension is, in fact, not required.

The most important features in the inspection of installation of high-strength bolts are:

- To know whether bolt pretension is required or not. If bolt pretension is not required, do not inspect for it.
- To know what pre-installation verification is required and to monitor it at the job site on a regular basis.
- To observe the work in progress on a regular basis.

Using acoustic methods, it is possible to determine the pretension in high-strength bolts that have been installed in the field with reasonable accuracy [28, 29]. However,

this process, which determines bolt pretension by sending an acoustic signal through the bolt, is uneconomical for all but the most sophisticated applications. The inspector and the designer must realize that it is a reality that the bolt pretension itself cannot be determined during the inspection process for most building and bridge applications. Therefore, the importance of the checklist just given cannot be overstated.

The S16-01 requirements for inspection are found in Clause 23.9. For further information and commentary, the RCSC Specification should be consulted.

3.4.2 Joints Using Snug-Tightened Bolts

For those joints where the bolts need only to be brought to the snug-tight condition, inspection is simple and straightforward. As described earlier, there is no verification procedure associated with snug-tightened bolt installation. The inspector should establish that the bolts, nuts, washers (if required), and the condition of the faying surfaces of the parts to be connected meet the requirements of the Standard. Hole types (e.g., oversized, slotted, normal) shall be in conformance with the contract documents. The faying surfaces shall be free of loose scale, dirt, or other foreign material. Burrs extending up to 1/16 in. above the plate surface are permitted. The inspector should verify that all material within the grip of the bolts is steel and that the steel parts fit solidly together after the bolts have been snug-tightened. The contact between the parts need not be continuous.

These requirements apply equally to A325 and A490 high-strength bolts and to A307 ordinary bolts.

3.4.3 Joints Using Pretensioned Bolts

If the designer has determined that pretensioned bolts are required, then the inspection process becomes somewhat more detailed than that required for snug-tightened bolts. Of course, the requirements already described for snug-tightened bolts are still applicable.

In the case of turn-of-nut pretensioning, routine observation that the bolting crew applies the proper rotation is sufficient inspection. Alternatively, match-marking can be used to monitor the rotation. However, it will be readily apparent that an air-operated impact wrench has been applied because the faces of the nut become peened during the installation operation.

Inspection of the installation of twist-off bolts is also by routine inspection. Since pretensioning of these bolts is by application of torque, proper storage and handling is particularly important. This should include a time limit between removal of bolts, nuts and washers from their protected storage and their installation.

Observation that a splined tip has sheared off is not sufficient evidence in itself that proper pretension exists, however. This only signifies that a torque sufficient to shear the tip was present in the installation history. It is important that twist-off bolts first be able to sustain twisting without shearing during the snugging operation. Thus, the inspector observe the pre-installation of fastener assemblies and assess their ability to compact the joint without twist-off of tips.

For direct-tension indicator pretensioning, routine observation can be used to determine that the washer protrusions are oriented correctly and that the appropriate feeler gage is accepted in at least half of the spaces between protrusions. After pretensioning, routine observation can be used to establish that the appropriate feeler gage is refused in at least half the openings. As was the case for twist-off bolts, simply establishing that the indicator washer gaps have closed can be misleading. The snug-tightening procedure must not produce closures in one-half or more of the gaps that are 0.015 in. or less.

When the joint is slip-critical, not only is the bolt pretension important but the condition of the faying surfaces must be inspected. The inspector should ensure that the contact surface condition provided is consistent with the contract documents and that the surfaces have not been contaminated at the job site. When surface preparation is done on the job site, e.g., for touch-up of

surfaces prepared in the shop, sufficient curing time before final joint assembly is important. Note that power wire brushing of galvanized surfaces is not permitted.

3.4.4 Arbitration

Both the S16-01 Standard and the RCSC Specification provide a method of arbitration for bolts that have been installed and inspected according to one of the approved methods but where disagreement has arisen as to the actual pretension in the installed bolts. A manual torque wrench is used to establish an arbitration torque that can then be applied to the bolts in question.

As is pointed out in the Commentary to the RCSC Specification, such a procedure is subject to all of the uncertainties of torque-controlled calibrated wrench installation. In addition, other elements necessary to control the torque-related issues may be absent. For example, an installation done originally by turn-of-nut with no washers will be influenced by this absence of washers when the arbitration inspection is applied. Passage of time can also significantly affect the reliability of the arbitration. There is no doubt that the arbitration procedures are less reliable than a properly implemented installation and inspection procedure done in the first place. Those responsible for inspection should resort to arbitration only with a clear understanding of its inherent lack of reliability.

Chapter 4

BEHAVIOR of SINGLE BOLTS

4.1 Introduction

The behavior of single bolts in tension, shear, or combined tension and shear is presented in this chapter. Features associated with each of these effects that are particular to the action of a bolt when it is part of a group, that is, in a connection, are discussed subsequently. Only the behavior of single bolts under static loading is discussed in this chapter: fatigue loading of bolted joints is presented in Chapter 7 and the effect of prying forces is discussed in Section 6.3.

4.2 Bolts in Tension

The load vs. deformation response of three different bolt grades was shown in Fig. 1.2. Such tests are carried out on full-size bolts, that is, they represent the behavior of the entire bolt, not just a coupon taken from a bolt. Consequently, the tests display the characteristics of, principally, the shank and the threaded portion. Obviously, strains will be largest in the threaded cross-section and most of the elongation of the bolt comes from the threaded portion of the bolt between the thread runout and the first two or three engaged threads of the nut.

The actual tensile strength of production bolts exceeds the specified minimum value by a fairly large margin [6]. For A325 bolts in the size range 1/2 in. to 1 in. diameter, the measured tensile strength is about 18% greater than the specified minimum value, (standard deviation 4.5%). For larger diameter A325 bolts, the margin is even greater. For A490 bolts, the actual tensile strength is about 10% greater than the specified minimum value (standard deviation 3.5%).

Loading a bolt in tension after it has been installed by a method that introduces torsion into the bolt during installation (i.e., by any of the methods described in Section 3.2) shows that its inherent tensile strength has not been degraded. The torque that was present during the installation process is dissipated as load is applied and the contact stresses reduce (see Section 3.2.1). Thus, the full capacity of the bolt in tension is available. In the case of bolts that were pretensioned during installation, the only other question that arises is whether the tension in the pretensioned bolt increases when a tension load is applied to the connected parts.

As discussed in Chapter 3, when a bolt is pretensioned it is placed into tension and the material within the bolt grip is put into compression. If the connected parts are subsequently moved apart in the direction parallel to the axis of the bolt, i.e., the joint is placed into tension, then the compressive force in the connected material will decrease and the tensile force in

the bolt will increase. For elastic conditions, it can be shown [6] that the resulting bolt force is the initial bolt force (i.e., the pretension) multiplied by the quantity $[1 + (\text{bolt area} / \text{plate area associated with one bolt})]$. For the usual bolt and plate combinations, the contributory plate area is much greater than the bolt area. Thus, the multiplier term is not much larger than unity. Both theory and tests [6] show that the increase in bolt pretension up to the load level at which the connected parts separate is in the order of only 5 to 10%. This increase is small enough that it is neglected in practice. Thus, the assumption is that under service loads that apply tension to the connected parts a pretensioned bolt will not have any significant increase in internal load. This topic is covered more fully in Chapter 6.

Once the connected parts separate, the bolt must carry the entire imposed external load. This can be easily shown with a free-body diagram. After separation of the parts, for example when the ultimate load condition is considered, the force in the bolt will directly reflect the external loads and the resistance will be that of the bolt acting as a tension link. Figure 4.1 shows diagrammatically how the internal bolt load increases slightly until the applied external load causes the connected parts to separate. After that, the applied external load and the force in the bolt must be equal.

In principle, the tensile design strength of a single high-strength bolt should be the product of a cross-sectional area, the minimum tensile strength of the bolt, and a resistance factor. The S16-01 rule for the capacity of a bolt in tension directly reflects the discussion so far. According to Clause 13.12.1.2 of the Standard, the factored tensile resistance of a bolt (T_r) is to be

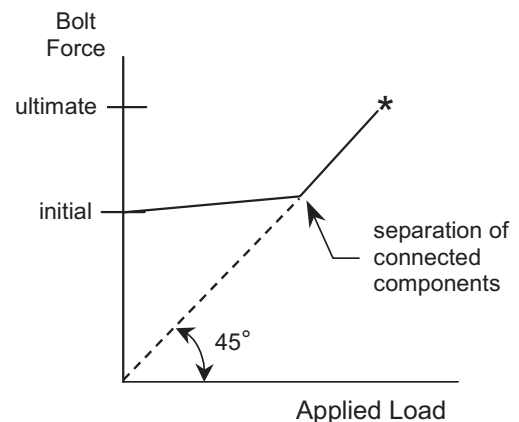

Fig. 4.1 Bolt Force vs. Applied Load for Single Pretensioned Bolt

calculated as—

$$T_R = 0.75 \phi_b A_b F_u \quad (4.1)$$

where ϕ_b = resistance factor, taken as 0.80

F_u = specified minimum tensile strength of the bolt

A_b = cross-sectional area of the bolt corresponding to the nominal diameter.

The tensile strength of a threaded fastener (T_R) should be the product of the ultimate tensile strength of the bolt (F_u) and some cross-sectional area through the threads. As described in Section 1.3, the area to be used is a defined area, the tensile stress area (A_{st}). It is somewhere between the area taken through the thread root and the area of the bolt corresponding to the nominal diameter¹⁰. Rather than have the designer calculate the area A_{st} , the Standard uses an average value of this area for bolts of the usual structural sizes corresponding to the bolt diameter—0.75 times the area corresponding to the nominal bolt diameter. Thus, the tensile strength $F_u A_{st}$ can be expressed as $F_u (0.75A_b)$, which is the form used in Eq. 4.1. Recall that the ultimate tensile strengths of A325 and A490 bolts (F_u) are 120 ksi and 150 ksi, respectively.

The same remarks apply generally to A307 bolts acting in tension. The tensile strength of A307 bolts is 60 ksi.

It was established in Reference [22] that a resistance factor $\phi = 0.85$ is appropriate for high-strength bolts in tension. This is also the value recommended in the *Guide* [6]. Thus, the choice of 0.80 for use in Eq. 4.1 is slightly conservative. To some extent, the choice reflects the fact that some bending might be present in the bolt, even though the designer calculates only axial tension.

As discussed, the strength of a single bolt in tension is a direct reflection of its ultimate tensile strength. However, there are several features that can degrade the strength when the bolt is acting in a connection. These are forces due to prying action, discussed in Chapter 6, and the other is the strength when fatigue is present, discussed in Chapter 7.

4.3 Bolts in Shear

The response of a single bolt in shear is shown in Fig. 4.2 for both A325 and A490 bolts. The type of test illustrated is done using connecting plates that are loaded in compression. Similar tests done using connection plates loaded in tension show slightly lower bolt shear strengths [6]. (The difference is the result of lap plate prying in the tension jig tests, which creates a combined state of stress,

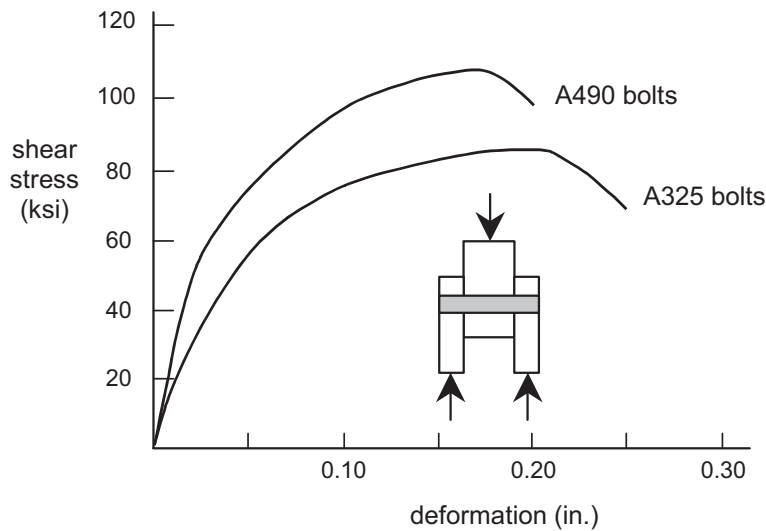

Fig. 4.2 Typical Shear Load vs. Deformation Curves for A325 and A490 Bolts

¹⁰ In the inch system of units, the tensile stress area is $A_{st} = 0.7854 (D - 0.9743/n)^2$, where D is the nominal bolt diameter in inches and n is the number of threads per inch.

shear plus tension, in the bolt.) It should be noted that there is little, if any, portion of the response that can be described as linear. Thus, the best measure of the shear capacity of a bolt is its ultimate shear strength. The use of some so-called bolt yield strength is not appropriate.

The tests show that the shear strength of a bolt is directly related to its ultimate tensile strength, as would be expected. It is found [6] that the mean value of the ratio of bolt shear strength to bolt tensile strength is 0.62, standard deviation 0.03.

An obvious question arising from the bolt shear tests is whether the level of pretension in the bolt affects the results. Test results are clear on this point: the level of pretension present initially in the bolt does not affect the ultimate shear strength of the bolt [6]. This is because the very small elongations used to introduce the pretension are released as the bolt undergoes shearing deformation. Both test results of shear strength for various levels of initial pretension and bolt tension measurements taken during the test support the conclusion that bolt pretensions are essentially zero as the ultimate shear strength of the bolt is reached. This has implications for inspection, among other things. If the capacity of a connection is based on the ultimate shear strength of the bolts, as it is in a so-called bearing-type connection, then inspection for pretension is pointless, even for those cases where the bolts were pretensioned.

The other feature concerning bolt shear strength has to do with the available shear area. If the bolt threads are intercepted by one or more shear planes, then less shear area is available than if the threads are not intercepted. The experimental evidence as to what the reduction should be is not conclusive, however. Tests done in which two shear planes were present support the idea that the shear strength of the bolt is a direct reflection of the available shear area [6]. For example, if one shear plane passed through the threads and one passed through the shank, then the best representation was obtained using a total shear area which is the sum of the thread root area plus the bolt shank area. These results support the position that the strength ratio between shear failure through the threads and shear failure through the shank is about 0.70, i.e., the ratio of thread root area to shank area for bolts of the usual structural sizes. On the other hand, in single shear tests this ratio was considerably higher, about 0.83 [35, 36]. At the present time, the difference is unresolved. Both the RCSC Specification [15] and the AISC LRFD Specification [37] use the higher value, slightly rounded down to 0.80. The S16 Standard uses the 0.70 value, however.

The S16–01 rule for the design strength of a bolts in shear follows the discussion presented so far. The rule is given in Clause 13.12.1.1 of the Standard, as follows:

$$V_r = 0.60 \phi_b n m A_b F_u \quad (4.2)$$

where n = number of bolts

m = number of shear planes

ϕ_b = resistance factor, taken as 0.80

F_u = specified ultimate tensile strength

A_b = cross-sectional area of the bolt corresponding to the nominal diameter.

Equation 4.2 follows directly from the discussion so far, given that the modifier 0.62 has been rounded down to 0.60.

Clause 13.12.1.1 also says that when lap splices have a joint length ≥ 15 times the bolt diameter, a reduction for the length effect must be made. If only one bolt is present, obviously that bolt carries all the shear load. If two bolts aligned in the direction of the load are present, each carries one-half of the total load. However, for all other cases, the bolts do not carry a proportionate share of the force. This is explained more fully in Section 5.1, where the reduction factor required by S16 for joint length is given.

The resistance factor used for bolts in shear (Eq. 4.2) is $\phi_b = 0.80$. Until the effect of joint length upon bolt shear strength is presented (Section 5.1), the selection of 0.80 cannot be fully discussed. However, it can be noted that the resistance factor recommended by the *Guide* [6], which is based on the study reported in Reference [22], is also 0.80.

4.4 Bolts in Combined Tension and Shear

Figure 1.5 showed how bolts can be loaded in such a way that both shear and tension are present in the bolt. Chesson et al. [38] carried out a series of tests on bolts in this condition, and these test results form the basis for the S16–01 rules. Two grades of fastener were tested: A325 bolts and A354 grade BD bolts. The latter have mechanical properties equivalent to A490 bolts. The test program showed that the only variable other than bolt grade that affected the results was bolt length. This was expected: as bolt length increases, bending takes place and the bolt shear strength increases slightly. (This is the consequence of the fact that the shear planes through a curved bolt are slightly larger than if the bolt were straight.)

An elliptical interaction curve was fitted to the test results [38]. The expression developed is given in the *Guide* [6]. It is applicable to both A325 and A490 bolts:

$$\frac{x^2}{(0.62)^2} + y^2 = 1.0 \quad (4.3)$$

where x = ratio of calculated shear stress (τ) to bolt tensile strength (σ_u)

y = ratio of calculated tensile stress (σ) to bolt tensile strength (σ_u)

The shear stress is calculated on the applicable area, the shank or through the threads, and the tensile stress is calculated on the tensile stress area.

Equation 4.3 can be restated using S16 notation as follows:

$$x = \frac{V_f/m A_b}{F_u} \quad y = \frac{T_f}{0.75 A_b F_u}$$

where V_f is the factored shear force, T_f is the factored tensile force, and m is the number of shear planes. In the expression for x , A_b is the actual area being sheared but in the expression for y , it is the bolt cross-sectional area corresponding to the nominal diameter. We recognize the denominator in the y -term as T_r , assuming that the ϕ_b

factor is yet to be inserted. Using these substitutions and writing Eq. 4.3 as an inequality, this can be written as

$$\frac{V_f^2}{(0.62 m A_b F_u)^2} + \frac{T_f^2}{T_r^2} \leq 1.0$$

Finally, we note that the denominator in the left-hand term is simply V_r and the interaction equation (for a single bolt) is written as

$$\left(\frac{V_f}{V_r}\right)^2 + \left(\frac{T_f}{T_r}\right)^2 \leq 1.0 \quad (4.4)$$

This is the requirements for bolt in combined shear and tension given in Clause 13.12.1.3 of the S16-01 Standard.

Chapter 5

BOLTS IN SHEAR SPLICES

5.1 Introduction

Figure 1.3 (a) showed a symmetric butt splice that uses plates to transfer the force from one side of the joint, say, the left-hand main plate, to the other, the right-hand main plate. (Most often, the main plate shown in this pictorial will actually be a structural shape like a W-shape, but the behavior can be more easily described using a plate.) Such a connection is used, for instance, to splice the chord of a truss.

The behavior of a large splice that was tested in the laboratory is shown in Fig. 5.1 [6]. This joint used ten 7/8 in. dia. A325 bolts in each of two lines. The holes were sub-drilled and then reamed to 15/16 in. dia., that is, they were 1/16 in. dia. larger than the bolts. The bolts were pretensioned using the turn-of-nut method. The plates were ASTM A440 steel and the measured strengths were 42.9 ksi static yield strength and 76.0 ksi ultimate. The slip coefficient of this joint was measured as 0.31.

The load vs. deformation response is reasonably linear until the joint slips. Following slip, which means that the plates are pulled up against the sides of at least some of the bolts, the joint at first continues to load at more or less the same slope as the initial region. Yielding of the connected material starts to occur, however, first in the net cross-section and then throughout the connected material. The ultimate load that this joint could carry corresponded to an average bolt shear stress of 67.0 ksi. However, tests of single bolts taken from the same manufacturing lot showed that the shear stress at failure was 76.9 ksi.

The behavior of this joint, which is reasonably representative of splices of this type, raises the following points:

- How much slip is likely to take place?
- Why is the average bolt shear stress at failure of the multi-bolt joint less than the bolt shear stress when a single bolt is tested?

If the bolts had not been pretensioned, the connected material would have been expected to pull up against the sides of the bolts at a relatively low load. In the case of the joint depicted in Fig. 5.1, this slip did not occur until the frictional resistance had been overcome, of course. In the most unfavorable condition, the amount of slip can be two hole clearances, i.e., 1/8 in. in this case. Since the bolts and their holes cannot all be expected to be in their "worst" locations, the amount of slip that actually takes place is observed to be much less than two hole clearances. In laboratory specimens, the amount of slip in such joints is about one-half a hole clearance [6], and values measured in the field are even less [39]. Thus, unless oversize or slotted holes are used, it can be expected that if joint slips occur they will be relatively small.

The reason that the average ultimate bolt shear stress in a multi-bolt joint is less than that of a single bolt can be explained qualitatively with the aid of Fig. 5.2. In plate *A* (the main plate) 100% of the load is present in the plate until the bolts start to transfer some load into the lap plates (plates *B* in the figure). Consider a high load, say, near ultimate. In plate *A* between bolt lines 1 and 2 the stress in the plate will still be high because only a small

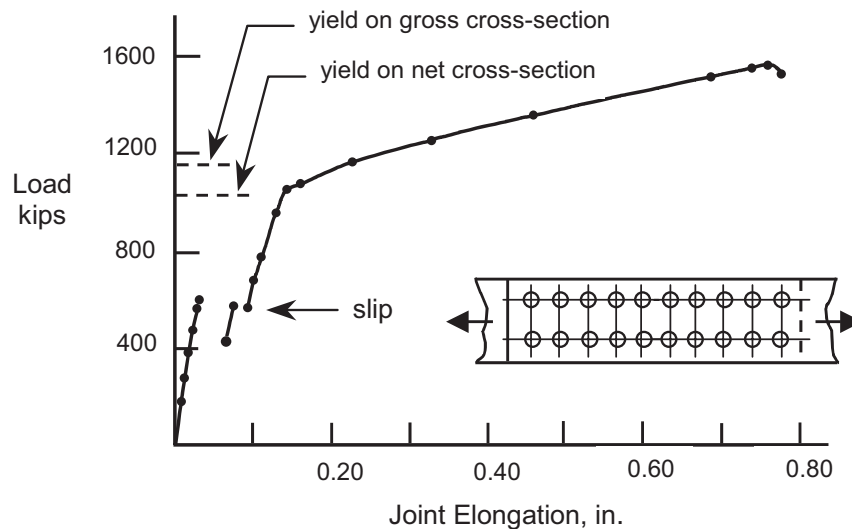

Fig. 5.1 Load vs. Elongation Behavior of a Large Joint

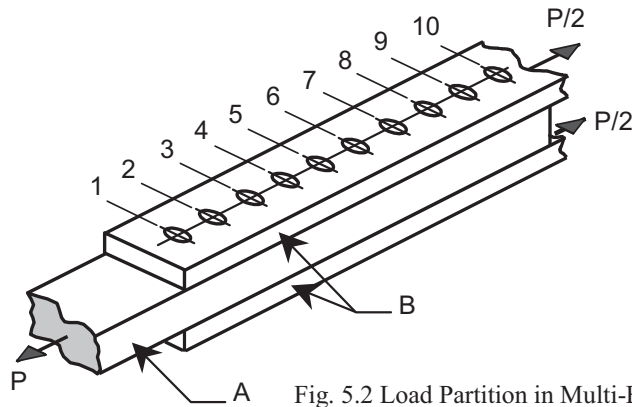

Fig. 5.2 Load Partition in Multi-Bolt Joint

amount of load has been removed (by bolt 1). Strains in this plate are correspondingly high. Conversely, the stress in the lap plates *B* between lines 1 and 2 is low because only a small amount of force has been taken out of the main plate and delivered to the lap plates. Thus, strains in the lap plates between bolt lines 1 and 2 will be low. This means that the differential in strain between plates *A* and *B* will be large in the region near the end of the joint.

Consider now the region near the middle of the joint, say, between bolt lines 5 and 6. Whatever the distribution of shear forces in the bolts, a considerable amount of the total joint force has now been taken out of plate *A* and put into plates *B*. Thus, the strains in the former have decreased as compared to the condition near the end of

the joint and the strains in the latter have increased. Consequently, the differential in strains between the two plate systems is less near the middle than it was near the end. Since the bolt shear force is the result of the imposition of these relative strains [6], bolts near the end of a joint will be more highly loaded than those toward the middle. It is worth noting that this uneven loading of the bolts in shear is accentuated as the joint load is increased from zero. It used to be argued that, even though the bolt shear force distribution was uneven at working loads, it would equalize as the ultimate load condition was reached. In fact, the converse is true.

The uneven distribution of forces in a multi-bolt shear splice can be seen in Fig. 5.3. Shown in this sawn section are the end four bolts in a line of 13. The top bolt (the end bolt) is close to failure, whereas the fourth bolt from the top has significantly less shear deformation and, hence, shear force.

The need for a reduction in the basic shear strength is discussed further in Section 5.3.

The designer must decide first whether a slip-critical connection is needed or not. If it is, then the appropriate design rules must be identified. If a bearing-type joint is satisfactory, then those design rules must be followed. (Bearing-type design implies both bolt shear strength and the bearing capacity of the connected material, as explained in Section 1.4). Because slip-critical joints are designed at the service load level, it is also a requirement that the ultimate strength criteria, i.e., the bearing-type joint rules, be met at the factored load level. The remaining sections in this Chapter will discuss these issues.

5.2 Slip-Critical Joints

Section 3.3 discussed the cases where slip-critical connections are needed. If proper functioning of the structure requires that a joint not slip into bearing, then this requirement is described as a *serviceability* limit state. In building design, which will be carried out in accordance with S16-01 [18], the requirement is that the joint not slip under the action of the service loads. (The

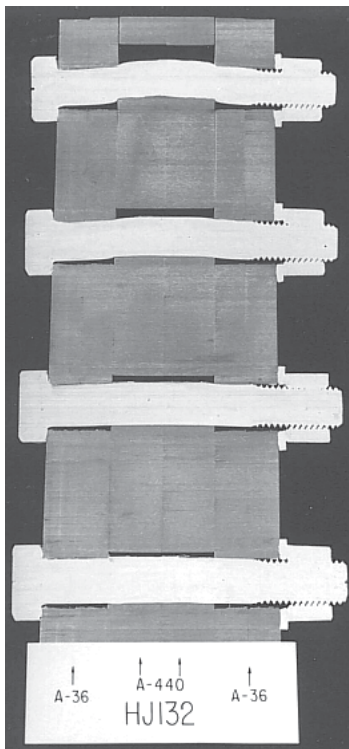

Fig. 5.3 Sawn Section of a Joint

service loads are the unfactored dead and live loads.) For the design of bridges, which will be done in accordance with S6-00 [20], prevention of slip is required under a force that includes the dead loads and 90% of the designated truck load, both of which are unfactored. In both cases (i.e., buildings and bridges) it is important to recognize that the same joint must also be designed as a bearing-type connection, this time acting under the factored loads.

From first principles, the slip resistance of a bolted joint can be expressed as:

$$P = k_s m \sum T_i \quad (5.1)$$

where k_s = slip coefficient of the steel

m = number of slip planes (n is usually either one or two)

T_i = bolt pretension (in each individual bolt)

Neither the slip coefficient nor the bolt tension forces are deterministic. They are reasonably represented as log-normally distributed and can therefore be characterized by a mean value and its standard deviation. Given this type of information, which is available from laboratory studies on full-size joints, it is possible to determine a probability of slip for given starting conditions [6]. The result reflects two important realities, described following.

As-delivered bolts have a tensile strength that is greater than the specified minimum tensile strength. For A325 bolts, this increase is about 20% and for A490 bolts it is about 7% [22]. A second observation is that the pretension in installed bolts will be greater than the specified minimum pretension, which is 70% of the bolt specified ultimate tensile strength.

In order to provide a design equation, a probability of slip must be selected. Based on past experience, this was taken by the *Guide* [6] to be about 5% when turn-of-nut installations are used. The examination at the time did not include twist-off bolts or bolts that use load-indicating washers. In the RCSC Specification [15], this design equation is written as:

$$R_s = \phi \mu D T_m N_b N_s \quad (5.2)$$

where

R_s = slip resistance of the joint

N_b = number of bolts

N_s = number of slip planes

μ = slip coefficient ($\equiv k_s$ in Eq. 5.1)

T_m = specified minimum bolt pretension

$D = 0.80$, a slip probability factor that reflects the distribution of actual slip coefficients about their mean value, the ratio of measured bolt tensile strength to the specified minimum values, and

the slip probability level (e.g., 5% in the case of turn-of-nut installation).

ϕ = modifier to reflect the hole condition (standard, oversize, short-slotted, long-slotted in direction of force, or long-slotted perpendicular to force). Note that the term ϕ in this equation is not the resistance factor usually associated with limit states design.

It can be seen that Eq. 5.2 is basically the same as Eq. 1, which expressed the slip load in fundamental terms. The modifier ϕ is used to reflect the decrease in bolt pretension that is present when oversize or slotted holes are used. The term D embodies the slip probability factor selected and provides the transition between mean and nominal bolt tension and slip values. In the form given by Eq. 5.2, the *Guide* can be used to obtain slip loads for other failure probabilities and various other conditions when necessary.

The S16 rules for design of slip-critical connections are presented in Clause 13.12.2.2. The slip resistance of a bolted joint is given there as—

$$V_s = 0.53 c_1 k_s m n A_b F_u \quad (5.3)$$

where k_s = slip coefficient of the steel

m = number of faying surfaces

n = number of bolts

A_b = cross-sectional area corresponding to the nominal diameter

F_u = specified minimum tensile strength of the bolt

c_1 and 0.53 = modifiers, described following.

According to the fundamental expression for the slip resistance (Eq. 5.1), we expect to see the product of the friction coefficient (k_s), the total clamping force, and the number of faying surfaces.

The clamping force is contained with the terms $0.53 n A_b F_u$. This grouping can be stated in a more fundamental way as $0.70 \times 0.75 n A_b F_u$. The multiplier 0.70 is used to reflect the requirement that the minimum pretension is to be at least 70% of the specified tensile strength of the bolt material, F_u . Next, it is convenient to use the area of the bolt corresponding to the nominal bolt diameter in Eq. 5.3, whereas it is really the stress area that should be used. The 0.75 multiplier is a reasonable conversion from nominal area to stress area for the bolt sizes employed in structural practice. The product of these two numbers, 0.70 and 0.75 is 0.53, which is what is used in Eq. 5.3.

All the terms in Eq. 5.3 have now been defined except for c_1 . This coefficient is used to relate mean slip coefficient values and the specified initial tension (i.e., 70% F_u) to a 5% probability of slip [6]. Values of both

c_1 and the slip coefficient, k_s , are given in Table 3 of the Standard. For slip-critical connections in which a greater probability of slip might be tolerable, information is available for the 10% level [6].

The slip resistance equation given in the S16 Standard (Eq. 5.3) is identical to that given in the RCSC Specification (Eq. 5.2) with one exception. The latter includes recognition that when oversize or slotted holes are present the slip resistance is less than projected. This is done using the ϕ term. In the RCSC Specification, $\phi = 1.0$ for standard holes (as would be expected), but is a number less than 1.0 for three other cases of slotted or oversize holes. Clause 13.12.2.2 of the S16 Standard, which presents Eq. 5.3, requires that a reduction factor of 0.75 be applied to the calculated slip resistance when long-slotted holes are present. (This covers one of the three reduction cases set out by the RCSC Specification.) This issue is discussed more fully in Section 8.3.

5.3 Bearing-Type Joints

5.3.1 Introduction

If it is not required that a joint be slip-critical, then the design issues are the shear capacity of the bolts and the bearing capacity of the connected material. These were the features contemplated in the discussion presented in Section 1.4. There has already been some discussion about the shear capacity of a single bolt (Section 4.3) and the effect of joint length upon bolt shear strength (Section 5.1). In Section 5.3, the bolt shear capacity discussion will be completed and the subject of bearing capacity in the connected material will be presented.

5.3.2 Bolt Shear Capacity

The S16-01 rule for the capacity of a bolt in shear was presented in Section 4.3. For convenience that information is repeated here—

$$V_r = 0.60 \phi_b n m A_b F_u \quad (4.2)$$

where V_r = factored shear resistance

n = number of bolts

m = number of shear planes

ϕ_b = resistance factor, taken as 0.80

F_u = specified ultimate tensile strength

A_b = cross-sectional area of the bolt corresponding to the nominal diameter

In Section 5.1, it was noted that the nominal shear strength of bolts in long lap splices must reflect the effect of joint length. The S16 Standard requires that when

$$L \geq 15 d$$

where L is the joint length (between the extreme bolts) and d is the bolt diameter, that the shear strength

calculated according to Eq. 4.2 be reduced by the factor $1.075 - 0.005 L/d$, but not less than 0.75. For many cases, especially shorter joints, this unnecessarily conservative [6].

As noted in the Standard (Clause 13.12.1.1), the joint length reduction factor is intended to apply only to lap splices. The joint length phenomenon does not apply to the bolts in web framing angels, for example.

The value selected for the resistance factor for bolts in shear, $\phi_b = 0.80$, is appropriate, as developed in Reference [22].

Design of bolts in shear must also recognize the location of the shear planes relative to the threads, as discussed in Section 4.3.

5.3.3 Bearing Capacity

The fashion in which the connected material reacts against a bolt that is loaded in shear was described in Article 1.4. Figure 1.6 (d) showed pictorially the bearing force acting against the connected material, and the actual effect of the contact between bolts and connected material can be seen in Fig. 5.3. The discussion in this section will deal with how the member (connected material) can reach its limit state in bearing and will also introduce the S16 Specification rules.

Figure 1.6 showed the action of a single bolt. If this bolt is close to the end of the connected part (see Fig. 1.6 (d)), then obviously one possible limit state is that a block of material will shear out between the bolt and the end of the end of the connected part. This is shown in Fig. 5.4. Other possibilities are that excessive deformations occur as the connected material yields or splitting takes place between the bolt hole and the end of the plate because of the presence of transverse tensile forces. Often, a combination of these features is observed in tests. The Standard simply sets a minimum end distance for bolts that will ensure that none of these failure modes take place. The rule is found in Clause 22.3.4, where the minimum end distance is generally a function of the bolt diameter except when only one or two bolts are in line with the direction of the force. In this latter case, the end distance is required to be 1.5 times the bolt diameter.

What is referred to as the bearing capacity of a bolt (σ_b) is really the bearing resistance of the plate adjacent to the bolt. For a single bolt, this can be written as

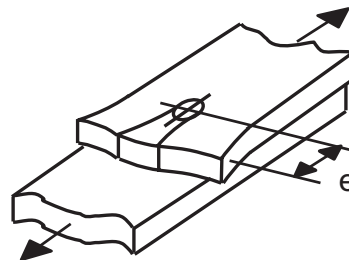

Fig. 5.4 End Bearing of a Single Bolt

$$B_r = \sigma_b d t \quad (5.4)$$

The assumption is made that the bearing pressure of the bolt acting upon the adjacent plate is spread over an area equal to the bolt diameter times the thickness of the plate. This is conservative since the bearing pressure will quickly spread out to a distance greater than the bolt diameter. Based on the test results [6], the relationship between bearing stress and plate ultimate strength (F_u) is observed to be

$$\frac{\sigma_b}{F_u} = \frac{e}{d} \quad (5.5)$$

In principle, the bearing capacity associated with a given bolt, B_r , can be obtained by substituting the value of the bearing stress obtained from Eq. 5.5 into Eq. 5.4. However, the test data show that this estimate of strength is valid only for ratios of e/d up to about 3. Beyond this limit, the failure mode changes gradually from one where the plate material shears out beyond the bolt to one in which large hole and plate deformations occur. For this reason, the Standard (Clause 13.10(c)) requires that

$$B_r = 3 \phi_{br} t d n F_u \quad (5.6)$$

Equation 5.6 is obtained by substituting the bearing stress σ_b given by Eq. 5.5, as described above, and setting the limit $e = 3d$. (In addition, the resistance factor ϕ_{br} has been introduced into the equation.)

In accordance with the concepts shown in Fig. 1.6, t must be the thinner of two connected parts. See also Fig. 5.4. If three (or more) plies are connected, t is the thinner of $t_1 + t_3$ or t_2 .

It would be reasonable to expect a design requirement to arise directly from Eq. 5.4, as indeed was the case in earlier editions of the Standard. However, the tearing out of material beyond a bolt (Fig. 5.4), or a group of bolts, is treated in S16 as part of the design requirements of a tension member. The phenomenon is called "tension plus shear block." Even though it is properly the subject of tension member design, it will be covered here (in Section 5.4) so that the reader can have the complete picture of how the fasteners in a bolted tension member behave. It should also be noted that only the requirement given by Eq. 5.6 needs to be considered for compression members. The phenomenon shown in Fig. 5.4 does not take place in compression member connections.

The resistance factor to be applied to the bearing capacity equation given in the S16 Standard is $\phi_{br} = 0.67$. This is reasonably consistent with the value calculated in Reference [22], where the number was determined to be 0.64.

5.4 Tension and Shear Block

A gusset plate connection is depicted in Fig. 5.5. Three features relating to application of the load are seen as the member (not shown) pulls on the gusset plate. These are elongation of the holes, shear yielding in the general vicinity of the holes and tensile fracture between the pair of holes at the bottom of the connection. The shear yielding is on planes generally parallel to the direction of the force and the tensile fracture is perpendicular to it. The connection shown corresponds to the ultimate load that the connection can carry. If the load is applied past this point, it reduces in magnitude and eventually a block

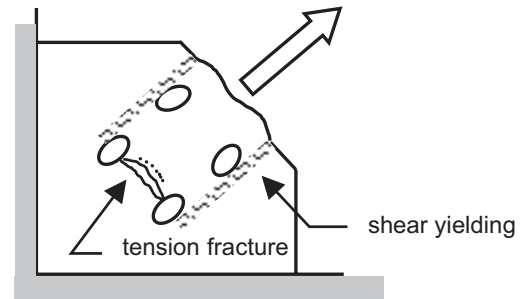

Fig. 5.5 Tension + Shear Block in a Gusset Plate

of material is separated from the gusset plate.

The principal design rule is based on this condition of shear yielding and tensile fracture [40, 41]. It is observed in tests that the shear yielding takes place more-or-less in the region next to the holes, i.e., the gross shear area (A_{gv}) will be engaged. The tensile fracture will take place at the net area (A_{nt}), which in Fig. 5.5 will be between the two holes. Accordingly, S16-01 describes the capacity of such a connection as the sum of the tensile resistance (T_r) and the shear resistance (V_r). The shear yield strength is expressed using the von Mises yield criterion, namely, $\tau_y = \sigma_y / \sqrt{3} \approx 0.60$. The rule is found in Clause 13.11(a)(i):

$$T_r + V_r = \phi A_{nt} F_u + 0.60 \phi A_{gv} F_y \quad (5.7a)$$

All the terms in this equation follow from the description of the behavior just given.

Depending upon the geometry of the connection, it is possible that the shear yield strength, $0.60 A_{gv} F_y$, could be greater than the shear fracture strength, $0.60 A_{gv} F_u$. In recognition of this, an upper limit to Eq. 5.7a is contained in the Standard, namely

$$T_r + V_r \leq \phi A_{nt} F_u + 0.60 \phi A_{nv} F_u \quad (5.7b)$$

In this case, the shear area to be used must be taken through the holes, i.e., A_{nv} .

The design rules for the type of connection shown in Fig. 5.5 will be applicable to any tension and shear block case as long as the connection is symmetrical about the

line of action of the applied force. For other cases, such as the end connection of a coped beam, the effect of the eccentricity will have to be included [40, 41] because the shear resistance is now present along only one side of the fastener group.

5.5 Shear Lag

For truss members, it is usual to transfer the force into or out of the member by means of gusset plates, as shown in Fig. 5.6. Generally, it is impractical to try to connect all of the cross-section of the shape. For instance, as illustrated in Fig. 5.6(a), the flanges of the W-shape are attached to the gusset plates, but the web is not directly connected. Consequently, the flow of stress from the bolts into the W-shape must be something like that shown in Fig. 5.6(b). Intuitively, it is to be expected that a long connection will be more favorable for this stress flow. Likewise, if the shape is shallow, the stress flow will be more favorable than if it is deep. The effects of these features of the geometry have been demonstrated in physical testing.

Another example is shown in Fig. 5.7, where a single angle is connected to a gusset plate. In this case, the outstanding leg of the angle is not connected. Again, an uneven distribution of stresses from the fasteners into or out of the angle is expected and the outstanding leg of the angle may not be fully effective. What this means, in both the illustrations used, is that the full cross-sectional area of the shape may have to be discounted (in addition to the fact that holes are present) in order to be able to predict the capacity of the member. This phenomenon is referred

to as *shear lag*.

The most obvious geometrical features that determine the severity of the shear lag are (a) the displacement of the centroids of the gusset plates relative to the member and (b) the length of the connection. (If the joint is particularly long, then that itself can also have an effect, as was explained in Section 5.1.) Physical testing has shown that other features such as the ductility of the material being joined, the method of making the holes (e.g., punched or drilled), the proximity of one hole to another, and so on, generally have a small influence.

Although a number of investigations have been performed to study the shear lag effect, the current North American design standards are based mostly on the work of Munse and Chesson [42, 43] This work included examination of different cross-sectional configurations, connections, materials, and fabrication methods. An empirical equation to calculate the net section efficiency was proposed. It was based on the test results of 218 specimens. This equation was verified further by a comparison with more than 1000 other test data. Using the assumption that the net area will be calculated using the so-called $s^2/4g$ rule and that the hole diameter will be taken as 1/16 in. greater than the actual hole size [20], then according to Munse and Chesson the predicted net section load of a tension member is given by

$$P_u = \left(1 - \frac{\bar{x}}{L}\right) A_n F_u \quad (5.8)$$

in which L and \bar{x} are terms that describe the geometry

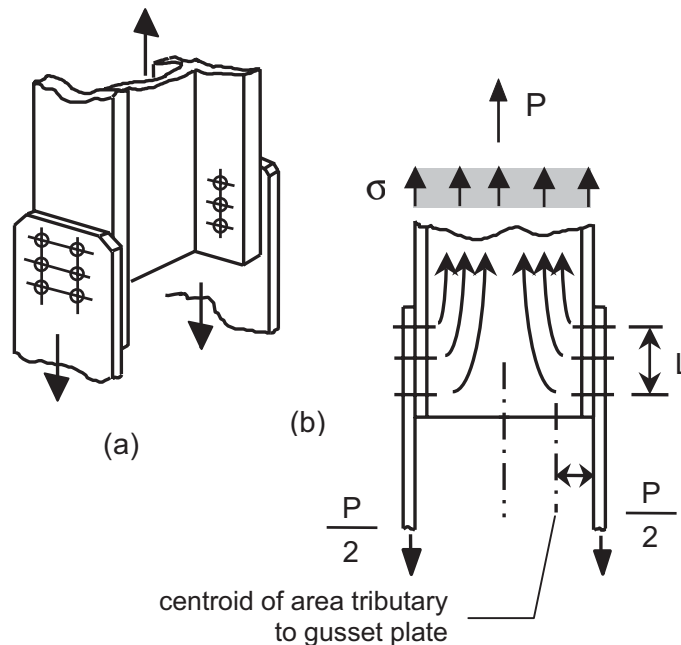

Fig. 5.6 Shear Lag in Gusset Plate Connection

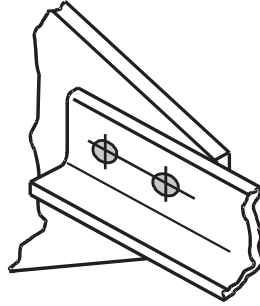

Fig. 5.7 Shear Lag in Angle Connection

(Fig. 5.6), A_n is the net cross-sectional area, and F_u is the ultimate tensile strength of the material.

Direct use of Eq. 5.8 presents a problem for the designer because the length of the connection, L , must be known (or assumed) before it can be applied. Thus, an iterative solution is indicated.

For many configurations, good approximations of Eq. 5.8 can be made and this is how the Standard deals with shear lag. Instead of using the net area, A_n , usually associated with the design of a tension member, an effective net area, A_{ne} , is defined according to the following schedule, found in Clause 12.3.3.2 of S16-01.

- (a) WWF, W, M, or S shapes with flange width not less than $2/3$ the depth (and structural tees cut from these shapes), provided the connection is to the flanges and there are at least 3 fasteners per

line of bolts: use $A_{ne} = 0.90 A_n$

- (b) Angles connected by only one leg—
four or more transverse lines of fasteners

$$A_{ne} = 0.80 A_n$$

fewer than four or transverse lines of fasteners

$$A_{ne} = 0.60 A_n$$

- (c) All other structural shapes connected with—
three or more transverse lines of fasteners

$$A_{ne} = 0.85 A_n$$

two transverse lines of fasteners

$$A_{ne} = 0.75 A_n$$

These approximations give satisfactory results for the cases described. For other situations or unusual connection geometries, Eq. 5.8 can be used directly.

Chapter 6

BOLTS in TENSION

6.1 Introduction

Connection configurations that place bolt groups into tension were first described in Section 1.4 (Types of Connections). In this Chapter, the connection of a tee-stub to a column flange (see Fig. 1.4(b)) will be used to discuss the issues. Two questions arise: (1) what is the relationship between the externally applied tensile load and the bolt pretension and (2) what force is carried by each bolt corresponding to the externally applied load, P .

6.2 Single Fasteners in Tension

Non-pretensioned bolts—A single bolt connecting two plates (infinitely stiff) that are loaded by an external force, P , is shown in Fig. 6.1(a). If the bolt has not been pretensioned, then the free-body diagram shown in Fig. 6.1(b) applies. This confirms that the single bolt shown must resist all of the external load that is applied to the part. The bolt simply acts like a small tension link and the least cross-sectional area should be employed to determine its capacity. Since the bolt is threaded, some reduced area (as compared with the unthreaded body portion of the bolt) must be used, and, because the thread is a spiral, the reduced area is greater than an area taken through the thread root. A notional area, the tensile stress area (A_{st}), that will accommodate this was introduced in Chapter 1 as Eq. 1.1. Hence the capacity of a single bolt that has not been pretensioned is simply the product of the tensile stress area and the ultimate tensile strength of the bolt, i.e.,

$$R_{ult} = A_{st} \sigma_u \quad (6.1)$$

If the bolt in Fig. 6.1 is preloaded, the obvious question that arises is whether the pretension and the force in the bolt that is the result of the external loading add in some way. This is discussed in the next section.

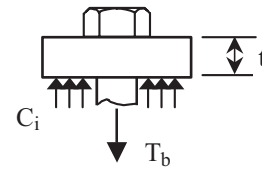

Fig. 6.2(a) Free Body: No External Load

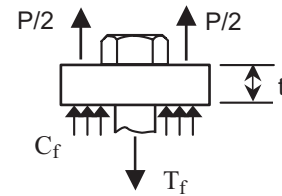

Fig. 6.2(b) Free Body: External Load Applied

Pretensioned bolts—Tightening the nut produces a tension force in the bolt and an equal compression force in the connected parts. The free-body diagram of Fig. 6.2(a) (bolt pretensioned but no external load applied) shows that

$$C_i = T_b \quad (6.2)$$

Figure 6.2(b) shows a free-body of the bolt, the adjacent plates, and an external load, P , that is applied to the connected parts. In this free-body, the tensile force in the bolt and the compressive force in the plate are identified as those corresponding to final conditions, T_f and C_f , respectively. The term of interest is the final bolt tension, i.e., by how much does the force in the bolt increase over its initial pretension value when the external load, P , is applied. This free-body indicates that

$$T_f = P + C_f \quad (6.3)$$

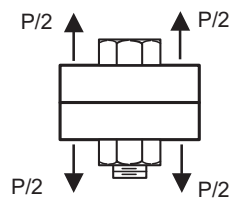

Fig. 6.1(a) Single Bolt and Tensile Force

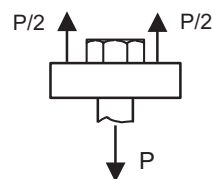

Fig. 6.1(b) Free Body Diagram

The plates and the bolt can be assumed to remain elastic,¹ and consequently the elongation of each component as the external force is applied can be calculated. The elongation of the bolt over a length equal to the thickness of one plate, t , is

$$\delta_b = \frac{(T_f - T_b)t}{A_b E} \quad (6.4)$$

As the external force is applied, the contact pressure between the plates, initially at a value C_i , decreases to some value C_f . During this process, the plate expands by an amount

$$\delta_p = \frac{(C_i - C_f)t}{A_p E} \quad (6.5)$$

where A_p is the area of plate in compression and is that associated with one fastener.

If the plates have not separated, compatibility requires that $\delta_b \equiv \delta_p$. Using Eq. 6.4 and 6.5, this means that

$$\frac{T_f - T_b}{A_b} = \frac{C_i - C_f}{A_p}$$

Using the value of C_i from Eq. 6.2 and the value of C_f that can be obtained from Eq. 6.3, and after some algebraic manipulation, the final bolt force can be obtained:

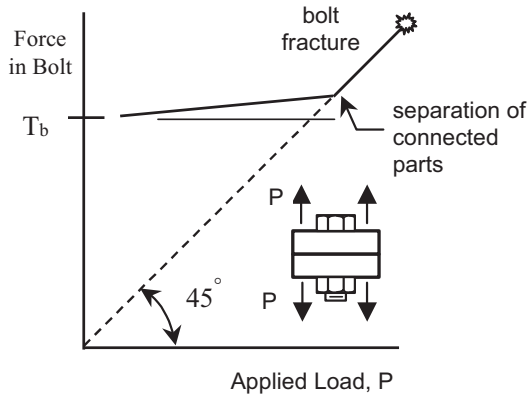

Fig. 6.3 Bolt Force vs. Applied Load

¹ The bolt will yield when pretensioning takes place, but the yielding is present only within a small portion of the total bolt volume. The assumption that the bolt is elastic is reasonable for the issue under examination.

$$T_f = T_b + \frac{P}{1 + \frac{A_p}{A_b}} \quad (6.6)$$

Equation 6.6 says that the final bolt force, T_f , is the initial pretension force, T_b , plus a component of the externally applied load that depends on the relative areas of the bolt and the area of the connected material in compression. Of course, the latter is not unique and there are other assumptions in the derivation of Eq. 6.6. However, test results [44] show that Eq. 6.6 is a good predictor and that the increase in bolt pretension can be expected to be in the order not more than about 5% to 10%.

After the parts have separated, Eq. 6.6 no longer applies and the situation is simply that corresponding to Fig. 6.1(b), i.e., the bolt must carry all of the externally applied force. In total, the response of the bolt to external load is that shown in Fig. 6.3.

The design requirements for high-strength bolts acting in tension can now be described. The small increase in bolt force that will occur as service loads are applied is ignored and therefore the S16-01 requirement will follow the strength expression given by Eq. 6.1. However, it is considered convenient that the designer not have to calculate the stress area of the bolt, A_{st} , in Eq. 6.1. Rather, the S16 design expression will use the cross-sectional area of the bolt corresponding to the nominal diameter. For most structural bolt sizes, the relationship between the two areas is about 0.75. With this adjustment to Eq. 6.1 and introducing the resistance factor ϕ_{st} , the expression for bolt tensile strength given in Clause 13.12.1.2 is

$$R_n = 0.75 \phi_b A_b F_u \quad (6.7)$$

which is a direct reflection of Eq. 6.1. The Standard requires that the resistance factor to be applied to is $\phi_b = 0.75$. This is somewhat greater than that recommended in [22], where the values given are 0.85 and 0.83 for A325 and A490 bolts, respectively. However, this is for bolts loaded using laboratory testing machines: similar bolts in real connections could have some bending present. Nevertheless, the S16-01 recommendation ($\phi_b = 0.75$) appears to be conservative.

The remaining question, how much force is carried by a bolt in a connection of real components, is addressed in the next section.

6.3 Bolt Force in Tension Connections

In the previous section, the resistance of a single bolt to an externally applied load was identified. In this section, the effect of the externally applied load acting upon a bolt group in which tensile forces develop will be examined. The need for this examination arises because the

deformation of the connected parts can produce forces in the bolts that are larger than the nominal values. For instance, the tee-stub connection shown in Fig. 6.4—which is a component of the connection shown in Fig. 1.4(b)—has four bolts connecting the flange of the tee to the column flange shown. It would normally be expected that the load per bolt is $P/4$. However, deformation of the connected parts can produce loads significantly greater than this.

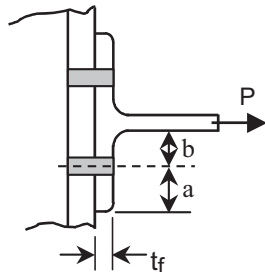

Fig. 6.4 Tee-Stub Connection

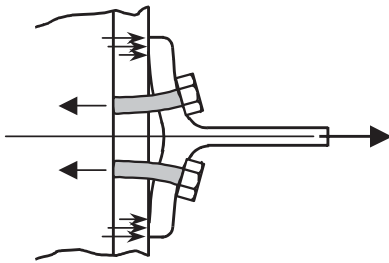

Fig. 6.5 Tee-Stub in Deformed Condition

Figure 6.5 shows the tee stub in a deformed condition. The drawing exaggerates the deformation, but it identifies that the tee stub flange acts like a lever upon the bolts. This result is termed *prying action*. Obviously, the amount of prying depends upon the stiffness of the flange, among other factors. If the flange is very stiff, then the bolt force vs. applied load relationship will be

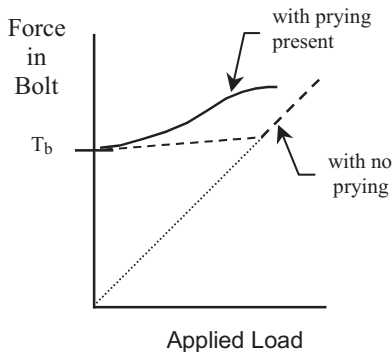

Fig. 6.6 Bolt Force vs. Applied Load, Prying Present

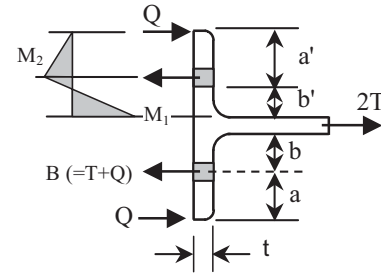

Fig. 6.7 Prying Action Nomenclature

like that in Fig. 6.3, which was for a single bolt loaded by an external force that acted upon an infinitely stiff part. If the flange is relatively flexible, then the relationship can be like that shown in Fig. 6.6. In addition to the stiffness of the flange, the other factors that can have the most significant effect upon the amount of prying are the bolt deformation capacity and the location of the bolt in the tee-stub flange (i.e., the dimensions a and b in Fig. 6.4).

Various models have been developed to quantify the bolt prying force. They are reviewed in Reference [6], where the model recommended is the one that was selected for use in the Handbook of Steel Construction [45]. Figure 6.7 shows the geometry of the model. It should be evident that selection of the dimension b should be as small as practicable (which will be for wrench clearance, mainly) so as to minimize the prying force, Q .

Summation of the forces gives

$$T + Q - B = 0 \quad (6.8)$$

A free-body taken from the flange tip to the centerline of the bolt (not shown) shows that

$$M_2 = Q \cdot a \quad (6.9)$$

Next, a free-body of the flange between the face of the tee-stub web and the bolt line (Fig. 6.8) and a summation of moments gives

$$M_1 + M_2 - T \cdot b = 0 \quad (6.10a)$$

The moments M_1 and M_2 act on different cross-sections, the former on the gross cross-section of the flange and the latter on the net cross-section, i.e., a cross-section taken through the bolt holes. In order to normalize Eq. 6.10(a), the moment M_2 will be multiplied by the ratio $\delta = \text{net cross-section} / \text{gross cross-section}$. Thus, Eq. 6.10(a) should be rewritten as:

$$M_1 + \delta \cdot M_2 - T \cdot b = 0 \quad (6.10b)$$

Also, it will be convenient to describe M_2 as a fraction, α , of M_1 , where $0 \leq \alpha \leq 1.0$:

$$M_1 + \alpha \cdot \delta \cdot M_1 - T \cdot b = 0$$

Solving for the moment M_1 —

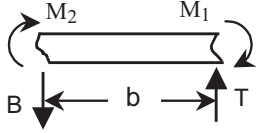

Fig. 6.8 Free-body Diagram

$$M_1 = \frac{T \cdot b}{1 + \alpha \cdot \delta} \quad (6.11)$$

Equation 6.9 can now be rewritten as

$$\alpha \cdot \delta \cdot M_1 = Q \cdot a$$

or,

$$Q = \frac{\alpha \cdot \delta}{a} M_1$$

Substitute the value of M_1 according to Eq. 6.11 to obtain the prying force

$$Q = \frac{\alpha \cdot \delta}{(1 + \alpha \cdot \delta)} \frac{b}{a} T$$

and then use Eq. 6.8 ($B = T + Q$) to obtain the final bolt force as

$$B = T \left[1 + \left(\frac{\alpha \cdot \delta}{1 + \alpha \cdot \delta} \right) \left(\frac{b}{a} \right) \right] \quad (6.12)$$

Reference [6] suggests using the dimensions a' and b' (Fig. 6.7) instead of a and b . This improves the agreement against test results and is slightly less conservative.

The result obtained using Eq. 6.12 can now be used to establish whether the bolt is adequate, in accordance with the limit states design Standard requirements (i.e.,

Eq. 6.7 multiplied by a resistance factor, which was also expressed as Eq. 4.1). A concomitant requirement is that the flexural strength of the tee-stub flange be adequate. The plastic moment capacity, $\phi M_p = \phi Z F_y$, is available since local buckling is not an issue. For a flange length w tributary to one bolt, this moment capacity is

$$\phi \frac{w t_f^2}{4} F_y$$

Setting this resistance equal to M_1 as given in Eq. 6.11 and solving for the flange thickness required—

$$t_f = \sqrt{\frac{4 T b}{\phi w F_y (1 + \alpha \cdot \delta)}} \quad (6.13)$$

Again, it is recommended that the dimensions a' and b' shown in Fig. 6.7 be used.

Examination of the connection strength using Eq. 6.12 and 6.13 requires knowledge of the value of α , which identifies the relationship between M_1 and M_2 . (If $\alpha = 1.0$, then there is a plastic hinge at each of the M_1 and M_2 locations (Fig. 6.7), and the prying force is a maximum. If $\alpha = 0$, then of course there is no prying action.) Information that is helpful regarding practical aspects of the use of Equations 6.12 and 6.13 is available in [51 and 52].

Often, it will be expedient to identify the plate thickness for which there will be no prying, i.e., $\alpha = 0$. If this plate thickness is acceptable in practical terms, then of course no further action is required except to ensure that the bolt chosen is large enough to carry the force T .

The issue of prying action is particularly important when the connection is subjected to fatigue. Chapter 7 should be consulted in this case.

Chapter 7

FATIGUE of BOLTED and RIVETED JOINTS

7.1 Fundamentals

Fatigue in metals is the process of initiation and growth of cracks under the action of repetitive load. If crack growth is allowed to go on long enough, failure of the member can result when the uncracked cross-section has been reduced to the point where it can no longer resist the internal forces or when the crack size is such that brittle fracture results. The fatigue process can take place at stress levels (calculated on the initial cross-section) that are substantially less than those associated with failure under static loading conditions. The usual condition that produces fatigue cracking is the application of a large number of load cycles.

It is inevitable that cracks or crack-like discontinuities are present in fabricated steel structures. The goal is to keep these within minimum acceptable limits, of course. As a generality, welded structures will have more flaws and discontinuities than will bolted or riveted structures.

The purpose of this chapter is to bring features of fatigue life analysis unique to bolted connections to the attention of the reader. Those who would like more background on fatigue and brittle fracture than is found here will find Reference [46] helpful.

7.2 Introduction to Fatigue of Bolted and Riveted Joints

High-strength bolted joints are often used in new structures when repetitive loads are present. Such situations include bridges, crane support structures, and the like. In many cases, the bolts will be in shear-type connections, and experience shows that the fatigue failure mode can be present in either the gross or net cross-section of the connected material. There are no reported instances of fatigue failure of the fasteners themselves when high-strength bolts are used in shear-type connections. However, in the case of connections that place the bolts in tension a potential failure mode is indeed fatigue failure of the bolts.

The fatigue life of riveted connections is of interest because of the need to establish the remaining fatigue life of existing structures that were fabricated in this way. Because of corrosion, old riveted structures, especially bridges, are unlikely to have the sound rivet heads that would be necessary to resist fatigue in the axial direction of the rivet. In such cases, the rivets should simply be replaced by pretensioned high-strength bolts. Consequently, the only case that will be discussed here is that for riveted joints loaded in shear.

Notwithstanding the distinction set out between fatigue of rivets or bolts in shear-type connections and rivets or bolts in tension-type connections, there are situations where both shear and tension are present. These cases are often inadvertent and arise because of deformation of connected parts or because of forces actually present but which have not been calculated by the designer. For example, a floor beam connected transversely to a girder by means of riveted or bolted web framing angles will be treated by the designer as a shear-only connection. Nevertheless, some moment will be present, particularly if the angles are relatively deep. Thus, a bolt or rivet designed only for shear can also have some tension present. This usually is not significant for strength, but it can show up as a fatigue failure in the fastener. This situation will not be treated here: the reader can obtain more information in References [46, 47].

7.3 Riveted Joints

The experimental evidence is that fatigue cracking in riveted shear splices takes place in the connected material, not in the rivet itself. Consequently, the fatigue life can be expected to be a reflection of such features as the size of the hole relative to the part, the method of hole forming (drilled, punched, or sub-punched and reamed), the bearing condition of the rivet with respect to the hole, and the clamping force provided by the rivet. At the present time, the influences of clamping force, bearing condition, and the method of hole formation have not been examined in any systematic way. The influence of the hole size, *per se*, is not likely to be strong, as long as the hole sizes and plate thicknesses commonly used in structural practice pertain. Thus, the best data available are tests on riveted connections of proportions that are consistent with usual structural practice and are of full size, or at least large size. For the time being, the effects of clamping force, bearing condition, and hole formation must simply be part of the data pool. For this reason, and because the "defect" presented by a riveted connection is not severe, it is to be expected that the scatter of data will be relatively large.

Figure 7.1 shows the experimental data, given here using SI units. Identification of the specific sources from which the test data came can be obtained in Reference [48]. Most of the data come from tests of flexural members, and most of these were members taken from service. For those cases where members taken from service were tested, the previous stress history was examined and deemed to have been non-damaging. A few of the test results are from tension members. In the case of bending members, the moment of inertia of the cross-section included the effect of holes. For the tension

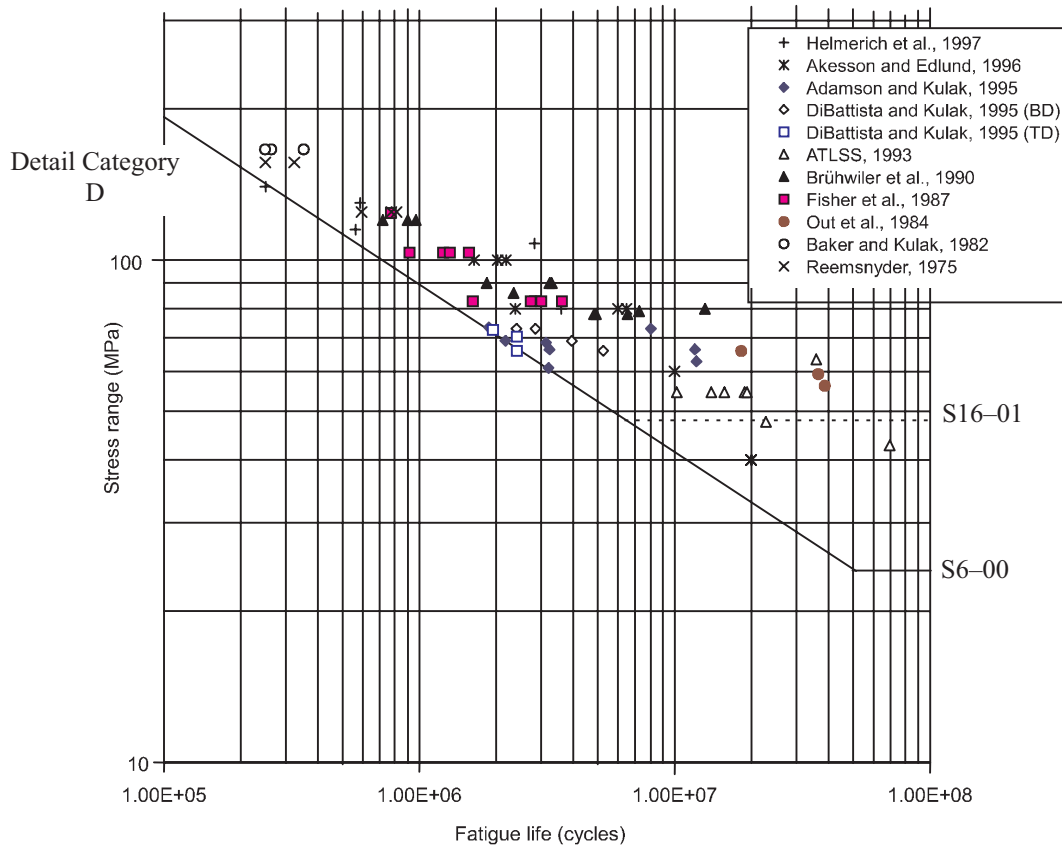

Fig. 7.1 Fatigue of Riveted Connections

members, the stress range was calculated on the net cross-section. (It is not yet clear whether this is justified. In the tests, it was observed that the fatigue cracks grew at right angles to the cross-section when staggered holes were present.)

It is usual to establish the permissible fatigue life for a welded detail as the mean of the test data less two standard deviations of fatigue life [46]. In the case of both riveted and bolted shear splices, however, there is a great deal of scatter in the results and the fatigue life line is selected more as a matter of judgment. Figure 7.1 shows the permissible stress range for riveted shear splices according to both the S16-01 Standard [18] and the S6-00 Standard [20]. In both cases, the net cross-section of the riveted member must be used to calculate the stress range.

The permissible stress range is the same (so-called Detail Category D) for the two specifications in the initial portion of Fig. 7.1, but there is a major difference in the long-life region. For the S16 Standard, the horizontal dotted line in Fig. 7.1 at the stress range value of 48 MPa (7 ksi) is the controlling feature in this region of fatigue lives greater than about 6.6 million cycles. The S6

Standard prescribes the same value, but then effectively discounts it by a factor of 2.

The constant amplitude fatigue limit, often abbreviated in the literature as CAFL and symbolically described in both of these Standards as F_{Srt} , is the stress range below which fatigue crack growth will not take place. In other words, the stresses are low enough that the crack will not lengthen. As implied by the title, the loading condition is restricted to constant amplitude fatigue. Most civil engineering structures subjected to repetitive loading will be undergoing variable amplitude fatigue. It is customary, and generally satisfactory, to use the constant amplitude fatigue results for both cases, however.

As seen in Fig. 7.1, the S6 constant amplitude fatigue limit does not start until about 50 million cycles. The adjustment is made in order to account for the presence of occasional stress ranges greater (by a factor of 2) than those corresponding to the calculated equivalent stress range [46]. This is reasonable and is consistent with the effects of observed highway truck traffic. Thus, the threshold stress in the S6 Standard is one-half of that used in the S16 Standard. There is an implication for the user of the latter: the stress ranges must be known exactly. If

even a very small number of cycles of otherwise constant amplitude fatigue stresses exceed the CAFL, fatigue crack growth can take place for all stress cycles. The number of cycles that exceeds the CAFL can be as little as 0.01% of the total and have an influence [49]. Thus, when applying the S16 rules, the designer must ensure that the calculated stress ranges in the long-life region will always be below the CAFL. One way of doing this is to use conservative assumptions regarding the applied forces. As described above, the S6 Standard handles this by a two-fold increase in the fatigue load.

It can also be observed (Fig. 7.1) that there are some test data at or below the S16 threshold limit of 48 MPa. The most important part of fatigue life predictions is the long-life region, which is precisely the area where there are the fewest test data. In the author's opinion, the S16 CAFL should be 40 MPa or less, not 48 MPa as now used.

There are other important differences in how the long-life region is handled. They are discussed below.

7.4 Bolted Joints

High-strength bolted joints can be subdivided into two categories; those that are lap or butt splices ("shear splices") and those that are tension-type connections. In the former case, the bolts can be either pretensioned or not pretensioned, although in new construction most specifications require that the bolts be pretensioned if fatigue loading is likely. It has always been common practice in bridge construction to use pretensioned bolts in slip-critical connections.

7.4.1 Bolted Shear Splices

The fatigue strength of a bolted shear splice is directly influenced by the type of load transfer in the connection. This load transfer can be completely by friction at the interface of the connected parts (slip-critical case, pretensioned bolts), completely by bearing of the bolts against the connected material (non-pretensioned bolts), or by some combination of these two mechanisms. In the case where the load transfer is by friction, fretting of the connected parts occurs, particularly on the faying surfaces near the extremities of the joint. Here, the differential strain between the two components is highest and, consequently, minute slip takes place in this location as load is applied repetitively. Cracks are initiated and grow in this region, which means that cracking takes place ahead of the first (or last) bolt hole in a line, and the crack progresses from the surface down through the gross cross-section of the component. The phenomenon is referred to as "fretting fatigue."

If the bolts are not pretensioned, load transfer is by shear in the fasteners and an equilibrating bearing force in the connected parts. The local tensile stress in the region of the connected part adjacent to the hole is high, and this is now the location where fatigue cracks can start and

grow. Some point at the edge of the hole or within the barrel of the hole is the initiation site for the fatigue crack, and growth is through the net cross-section of the connected part.

Both types of fatigue crack behavior have been observed in laboratory tests and, in a few cases, both types have been observed within the same test. If non-pretensioned bolts are used, it is highly unlikely that fretting fatigue will occur, however. When pretensioned bolts are used, it is prudent that the designer check both possible types of failure.

It is worth noting again that there is no history of fatigue failure of high-strength bolts themselves in shear splices. Only the connected material is susceptible to fatigue cracking.

Figure 7.2 shows the fatigue design resistance as a function of the number of stress cycles for the S16 Standard. Most of the detail categories are for welded details, but Detail Category D in this figure was also shown in Fig. 7.1, where it applies to riveted details. In Fig. 7.2, the long-life region has alternative slopes, either zero (horizontal) or five. The features associated with these will be discussed later.

Figure 7.2 also illustrates a principal feature of the fatigue life behavior of fabricated steel details, namely, that there is a linear relationship between log stress range and log number of cycles. (Stress range is the algebraic difference between the maximum stress and the minimum stress.) In equation form, this is

$$\log N = \log M - m \log \Delta\sigma_r \quad (7.1)$$

where N is the number of cycles of the stress range $\Delta\sigma_r$, m is the slope of the $\log N$ vs. $\log \Delta\sigma_r$ line, and M is a constant obtained from physical testing. Equation 7.1, or its equivalent

$$N = M \Delta\sigma_r^{-m} \quad (7.2)$$

is used as the basis for the permissible fatigue resistance expressed in both the S16 and the S6 Standards.

Both of these standards assign bolted slip-critical connections to Detail Category B. As discussed above, the stress range is to be calculated using the gross cross-section because that is where the fatigue cracks will occur. The test data show that Category B is a reasonable lower bound [6]. However, a closer examination of the data shows that the slope of the fatigue response line is not 3, as used in the initial region for all detail categories, but is more like 5. Nevertheless, the use of Category B is satisfactory.

Both Standards describe a category "high-strength bolted non-slip-critical connections," and it is to be used in conjunction with the net section. The Detail Category is B. It is difficult to know what is meant by a "non-slip-critical connection." Most engineers would likely conclude that this is meant to describe a bearing-type

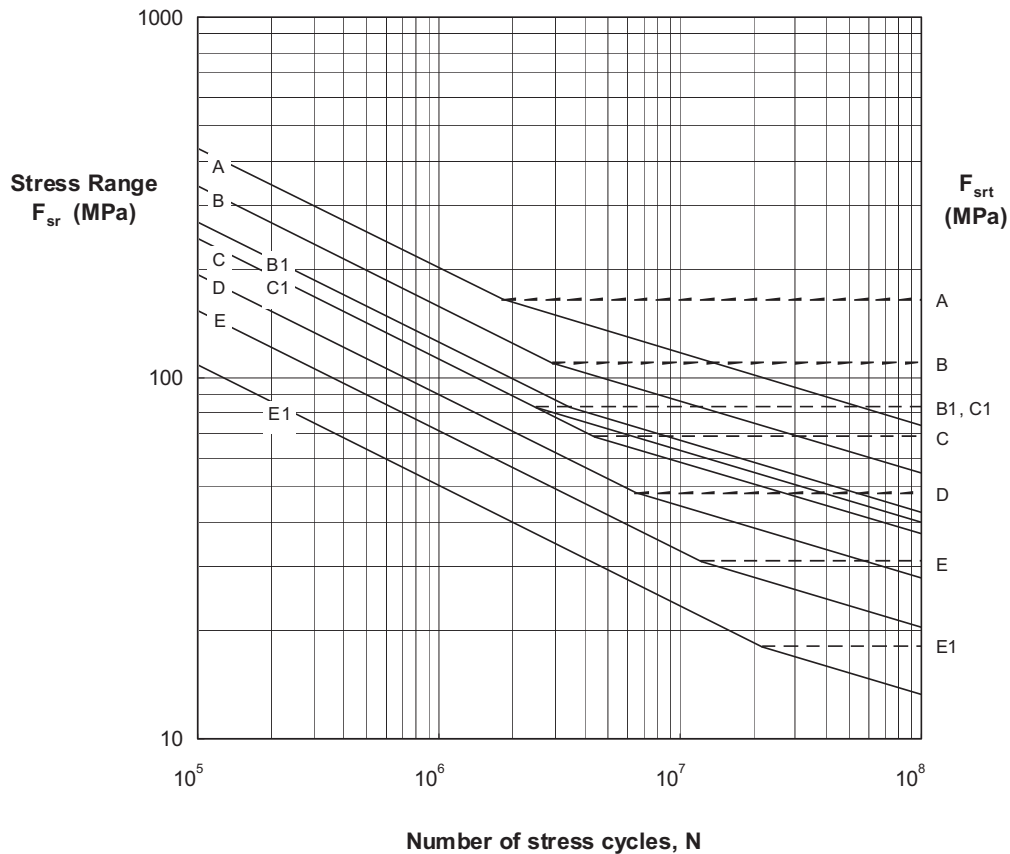

Fig. 7.2 Fatigue Design Rules According to S16

connection. If a high-strength bolted connection is used in which no bolt pretension is present, then it should be expected to be more or less the same as a riveted connection, i.e., a Detail Category D. The author's advice is to use Category D if a true bearing-type connection is to be examined for fatigue. Better information is now available [50] for this case, including how to calculate the stress range in the presence of staggered holes, a common situation.

The category identified by the Standards as a "non-slip-critical connection" most likely was intended to mean a bolted joint that has been pretensioned but where slip into bearing has occurred [6]. In this case, bolt pretension remains and the load transfer will be by a combination of friction resistance, shear in the bolts and bearing in the connected material.

In applying any of these design criteria, the distinction made by the two standards in the long-life region, as described in Section 7.3 for riveted joints, also applies to bolted joints.

There are many examples where fatigue cracking is the consequence of out-of-plane deformations [46, 47]. This is referred to as displacement-induced fatigue cracking. The S6 Standard provides some guidance for

such situations, but the S16 Standard makes only passing mention. Elimination of displacement-induced fatigue cracking is largely a matter of good detailing, which is a difficult thing to quantify. However, References [46 and 47] and the AASHTO Specification [51] are helpful sources. Designers are reminded that meeting the rules for force-induced fatigue design, as has been discussed in this chapter, does not eliminate the need to examine the possibility of distortion-induced fatigue cracking.

Accommodation of different stress ranges is done using the Palmgren–Miner summation [46], which is simply a linear damage accumulation rule. The S6 and S16 Standards differ in how stress ranges in the long-life region of the fatigue response are handled, however. S6 assumes that the fatigue response is an initial region at a slope of -3 followed by a region where the slope is zero. Figure 7.1 illustrates this approach. The S16 Standard also uses a slope of -3 in the initial region, but this is followed by a region where the slope is -5 . This approach is shown in Fig. 7.2. There is lack of agreement as to which approach is more representative of what actually happens, but the evidence at the present time seems to support the S16 approach.

7.4.2 Bolts in Tension Joints

Although there are few, if any, reported fatigue failures of high-strength bolted shear splices, fatigue failures of high-strength bolted tension-type connections have occurred from time to time. Fortunately, it is not usual to use tension-type connections in bridges and other repetitively loaded structures. The experimental data upon which to base design rules are not very numerous, however.

Connections that result in bolts in tension were illustrated in Fig. 1.4. A significant feature of the connection is that prying forces develop, and it was explained in Chapter 6 that this places an additional force in the bolt, thereby increasing the nominal tension value (i.e., the total external force divided by the number of bolts). The amount of the prying force is dependent upon the flexibility of the connection. The same flexibility introduces bending into the bolt, and this will adversely affect the fatigue life of the bolt. The threaded portion of the bolt provides the crack initiation location, which as a rule is at the root of a thread. It should be noted that the predictions for prying force given in Chapter 6 are based on conditions at ultimate load. The level of prying force at service load levels, which is where fatigue takes place, has not been established by either analysis or tests.

The stress range experienced by the bolt as the assembly undergoes repeated loading is significantly affected by the level of bolt pretension [6]. At one extreme, properly pretensioned bolts in a very stiff connection will undergo little or no stress range and will therefore have a long fatigue life. On the other hand, if the connection is relatively flexible, bolt bending is present, and the bolt pretension is low, then the stress range in the bolt threads will be large. Bolts in this condition will have a short fatigue life. An additional complication occurs if the applied load is high enough to produce a significant amount of yielding in the fasteners. In this case, it has been shown that the stress range increases with each cycle [6].

The available test data are in References [52 and 53]. Fatigue was not the primary purpose of either experimental program and the test parameters that relate to fatigue are limited. The tests did show that the actual stress range in a bolt that is properly pretensioned and where the prying forces are small is substantially less than the nominal stress range. (The nominal stress range is the nominal load per bolt divided by the bolt tensile stress area.)

The S6 requirements for bolts in tension-type connections follow the same general pattern as that for other details. However, it is noted that the bolt prying force must not exceed 30% of the nominal force in the bolt. It is also pointed out that the stress range is to be

calculated using the area of the bolt corresponding to the nominal diameter. This is simply a convenience that can be employed because the ratio between the area through the threads and that corresponding to the nominal diameter of the bolt is relatively constant for the usual bolt sizes. If fatigue failure does take place it will be at the threaded portion.

The S6 rules provide a sloping straight line in the short life region, followed by a horizontal straight line at the level of the constant amplitude fatigue limit, as is usual for all details. However, the sloping straight line portion is short and the constant amplitude fatigue limit (CAFL) will govern for most cases. For A325 bolts, the CAFL (214 MPa) starts to govern at only about 57,000 cycles if the CAFL is taken at its tabulated value. If the CAFL is divided by 2, as was explained in Section 7.3, then the sloping straight line intersects the CAFL/2 line at 458,000 cycles. For A490 bolts, the CAFL is 262 MPa, and, again, the sloping straight line portion of the fatigue life curve is relatively short. Although the S6 Standard rules capture the test data in a reasonable way, it does not seem justified to use the sloping straight line portions. It can also be observed that the test data do not indicate a differentiation between A325 and A490 bolts, which is the position taken in the S6 Standard.

The S16 Standard simply provides constant values for the fatigue life response for high-strength bolts acting in tension. These values are 214 MPa and 262 MPa for A325 and A490 bolts, respectively. Like the S6 Standard, S16 also requires that calculated prying forces be not greater than 30% of the nominal values.

In S16, the designer has the option of (1) determining the stress range by analysis, using the relative stiffness of the various components of the connection, including the bolts, or (2) by simply calculating the stress range (on the body area) using the specified loads and including the prying forces. Given the difficulty of calculating the stress range, it is likely that designers will use the second option.

As already indicated, there are very few data available for development of fatigue life rules for high-strength bolts. Some work is currently (2004) underway.

The fatigue design of high-strength bolts that are in tension-type connections should reflect the following guidelines:

- Whenever possible, reconfigure the connection so that the bolts are in shear, not tension.
- Ensure that proper installation procedures are followed so that the prescribed bolt pretensions will be attained.
- Design the connection so that prying forces are minimized.

Chapter 8

SPECIAL TOPICS

8.1 Introduction

There are a number of issues that are of interest to designers but which do not warrant an extensive discussion here because of the amount of detail involved. The specifics can be obtained expeditiously by reviewing the relevant specifications when required. The miscellaneous subjects covered in this Chapter include the need for washers, use of oversized or slotted holes, use of particularly short or particularly long bolts, galvanized bolts and nuts, reuse of high-strength bolts, joints that combine bolts and welds, and presence of coated faying surfaces. The short discussions associated with these topics are intended mainly to alert the designer to the issues involved and to potential problems.

8.2 Use of Washers in Joints with Standard Holes

Clauses 23.5.1 and 23.5.2 of the Standard outline the situations when standard hardened washers, ASTM F436 [17], must be used. These include installations involving pretensioned twist-off bolts (F1852) and when the arbitration method of inspection is to be employed. In both these instances, the use of a hardened washer under the turned element is intended to provide a reasonably consistent frictional surface. No washer is required under the non-turned element for these situations.

A washer is also required for the installation of bolts that use a washer-type direct tension indicator (F959). Although this is not a torque-controlled method of installation, there are reasons specific to the way this installation is performed that mean that washers are usually required. These reasons include (a) the necessity that the protrusions on the F959 washer bear against a hardened surface and (b) the need to prevent these protrusions from wearing down by scouring, as could be the case if a nut or bolt head is turned directly against the protrusion side of this washer. Standard washers are not required when the F959 washer is placed against the underside of the bolt head if the head is not turned, however. Specific information as to the location of the washer can be obtained in Article 6.2.4 of the RCSC Specification. Another helpful source for identifying washer locations when F959 washers are used (and other similar bolting detail information) is Reference [54].

When A490 bolts are used to connect steel with a specified yield strength of 280 MPa or less, hardened washers are required under both the nut and the bolt head. The requirement reflects the desire to have a hard, non-galling surface under the turned element and one that will not indent under the high pretensions attained by A490 bolts. Most steels in use today will exceed the 280 MPa strength limit, however. Notwithstanding that washers are

not needed for most A490 bolt installations, use of a washer under the turned element can reduce installation time, particularly for larger diameter A490 bolts.

When snug-tightened joints are used, washers are not required, except as noted below. Likewise, for slip-critical joints that use A325 pretensioned bolts, washers are not generally required. There are certain exceptions, and these are noted as follows:

- If sloping surfaces greater than 5% (i.e., 1:20) are present, an ASTM F436 beveled washer must be used to compensate for the lack of parallelism. This applies to both A325 and A490 bolts.
- Washers are often required for joints that use slotted or oversized holes, regardless of the type of joint or method of installation. This is discussed in Section 8.3.

Fastener components are typically supplied by the manufacturer or distributor as separate items, i.e., bolts, nuts, and washers. Assembly of the components into "sets" is sometimes done at this point in order to make it convenient for the installer of the assembly. If washers are not, in fact, required by the specifics of the application, using these washers means that the time required to place the bolts will be slightly increased because of the extra handling required in the installation. On the other hand, using washers throughout a job means that the erector does every joint in a consistent manner. If this is the method chosen, it is at least worthwhile that the inspection process reflect whether the washers were actually needed.

8.3 Oversized or Slotted Holes

The use of oversized or slotted holes can be of benefit to erectors because their use allows more tolerance when placing the components of the assembly. The question to be addressed here is the effect that oversized or slotted holes might have upon the expected performance of the connection.

The standard hole size for high-strength bolts is 2 mm greater than the nominal diameter of the bolt to be used. Particularly in joints that have many bolts, it is possible that not all the holes in one component will line up exactly with the holes in the mating material. However, if oversized holes are used, omnidirectional tolerance exists. If slotted holes are used, a greater tolerance is provided than for oversized holes, but this tolerance is mainly in one direction, the direction of the slot. The Standard differentiates between "short" slots and

"long" slots, dimensions that are defined in Clause 22.3.5.2.

The effect of oversized or slotted holes upon net section is taken into account directly in the design calculations because the oversized hole or slot dimensions will be used. Therefore, the concern becomes one relating to the bolt behavior—will the bolt in a slotted hole or an oversized hole be reduced in capacity as a consequence.

The situations in which only snug-tightened bolts were required were set out in Section 3.3. By definition, no pretension is present for this case and, consequently, it can be assumed that there is no load carried by friction. Slip into bearing could take place at relatively low loads, meaning service loads, in this situation. The S16 Standard therefore requires that when snug-tightened bolts are specified, only standard holes should be used so that the amount of joint slip will be minimal and will likely take place during the erection process. If short-slotted or long-slotted holes oriented perpendicularly to the direction of load are used, then snug-tightened bolts without washers are permitted because potential slip will be similar to that for standard holes in the direction of load. In summary, standard holes and short-slotted or long-slotted holes oriented perpendicularly to the direction of load are permitted when the bolts are snug-tightened only. Oversize holes are not permitted.

Oversize holes can be used in any or all plies of slip-critical connections but they cannot be used in bearing-type connections, as already noted. In the former, slip will not take place up to the service load level and so the increased clearance provided by oversize holes is not relevant. In the case of bearing-type joints, slip could take place at even relatively low loads, and so oversize holes are not permitted.

When oversize holes are used in slip-critical connections, standard (F436) washers must be used against such holes if they are present in the outside plies.

Short-slotted holes can be used in any or all plies of slip-critical (any direction) or bearing-type connections (must be perpendicular to the direction of load).

Long-slotted holes can be used in slip-critical joints without regard to the direction of loading but the slip resistance must be reduced. As was noted in Section 5.2, a reduction factor (ϕ) equal to 0.75 is applied to the slip resistance calculation when long slots are present. As was the case for short slots, long-slotted holes can be used in bearing-type connections if they are oriented perpendicularly to the direction of the load. The reduction factor is applied because, in the unlikely event that slip would take place, the amount of slip would be relatively large.

A long slot may be used in only one of the connected parts at a faying surface (either bearing-type or slip-critical). When long slots are present in an outer ply, structural plate washers or a continuous bar washer not less than 8 mm thick shall be used to bridge the slot. Note

that this requirement will not be satisfied by simply stacking individual standard (F436) washers: the issue is one of stiffness, not strength.

If the joint is slip-critical, then washer requirements reflect the fact that intended bolt pretensions may not be attained with standard washers. Tests have shown that both oversized and slotted holes can affect the level of preload in the bolt when standard installation procedures are used. Consider an oversized hole, for example. As a hole becomes larger relative to the bolt diameter, the amount of material remaining to react the force in the bolt is reduced. Consequently, the connected material around the periphery of the hole is under higher contact stresses than would otherwise have been the case. This is exacerbated if the bolt head, nut, or washer actually scours the connected material. The situation is similar when slotted holes are used. As a result, the amount of bolt elongation (and, pretension) for a given turn-of-nut will be less than if a standard hole were present.

Tests have shown that using standard washers, which are 5/32 in. thick¹, often does not permit the expected bolt pretensions to be attained when oversized or slotted holes are used. A greater washer thickness (i.e., stiffness) is required to bridge the opening and enable the delivery of normal pretensions. The RCSC Specification does permit F436 washers for a certain number of cases—all diameters of A325 bolts and A490 bolts ≤ 1 in. diameter when oversized or short-slotted holes are present in the outer plies of a joint. However, when a long-slotted hole is used in the outer ply, a 5/16 in. thick plate washer or continuous bar is required. For the case of A490 bolts >1 in. diameter and oversized or short-slotted holes in an outer ply, an ASTM F436 washer with 5/16 in. thickness is required. If the A490 bolt is used when a long-slotted hole is present in the outer ply, then a 5/16 in. thick hardened plate washer or hardened continuous bar is required. As already discussed, building up to a required thickness by simply stacking standard washers is not sufficient. The requirement to be met is one of stiffness, not thickness *per se*.

8.4 Use of Long Bolts or Short Bolts

Long or short bolts not required to be pretensioned do not require special attention. However, when pretension is required, the use of particularly long or short bolts should be scrutinized.

The bulk of the research used initially to formulate the rules for the installation of high-strength fasteners was done using bolts where the length was generally in the

¹ ASTM A436 washers have a maximum permitted thickness of 0.177 in. for all bolt diameters, but the minimum permitted thickness is a function of the bolt diameter. A reasonable average value for the thickness is usually taken as 5/32 in. (0.156 in.).

range of about 4 bolt diameters up to about 8 diameters [6]. Subsequently, it was found that if the bolts were shorter than this, then the installation process could produce torsional failure of the bolts or thread stripping before installation had been completed. At the other end of the spectrum, the use of long bolts means that more elastic relaxation will be present and this may degrade the pretension. For very long bolts, there simply is not enough research background for satisfactory standard pretensioning and installation rules to be set forth and pre-installation testing is required. Again, these concerns about short or long bolts apply only when pretension is required.

The S16 Standard requires that short bolts that will be pretensioned according to the turn-of-nut process be given 1/3 turn instead of the usual 1/2 turn. This applies to bolts whose length is up to 4 diameters. If other methods of installation are chosen, use of direct tension indicating washers or tension-control bolts, then the length effect will be captured in the pre-installation testing. A problem can arise with particularly short bolts, such as may be used in tower construction, however. Depending on the size of the Skidmore-Wilhelm calibrator, it may not be possible to properly fit the bolt into the calibrator. Either new fittings must be used to adapt the calibrator to the short bolts, or calibrated direct tension indicating washers be used, or a solid block device that measures load using strain gages can be improvised.

In the case of long bolts that must be pretensioned, if the turn-of-nut method is used and the bolts are between 8 diameters and 12 diameters, then 2/3 turn should be used. Bolts greater than 12 diameters long have not been subjected to sufficient testing to establish rules. For long bolts that will be installed using direct tension indicating washers or for tension-control bolts, calibration using the Skidmore-Wilhelm device is easily accomplished by the addition of solid material sufficient to increase the grip length.

8.5 Galvanized Bolts

In order to provide corrosion protection, it is sometimes advantageous to apply a zinc coating to structural steel, i.e., to galvanize the material. In these cases, it is usually the practice to use galvanized fasteners as well. In ordinary conditions, the high-strength bolts themselves do not exhibit very much corrosion, and it is generally unlikely that corrosion protection of the bolts is necessary for most building construction unless there is exposure to a marine atmosphere. The industrial atmosphere of some plants may make it desirable to galvanize high-strength bolts in these cases also. In no instance should A490 bolts be galvanized, however, because their high strength makes them susceptible to hydrogen embrittlement.

The effects of galvanizing A325 bolts is discussed in this section. The effect of galvanizing the connected material is examined in Section 8.8.

The issues raised when a bolt and nut are galvanized include any possible effect on the strength properties of the bolt, the potential for nut stripping because of thread overtapping, and the influence of the zinc coating on the torque required for installation.

Research has shown that galvanizing has no effect on the strength properties of the bolt [6], which is what would be expected.

The friction between the bolt and nut threads is increased when a bolt and nut are galvanized. The galvanizing has two effects. First, it increases the variability of the relationship between applied torque and resultant pretension. At the extreme, a galvanized bolt and nut can twist off before the desired pretension has been attained. Second, thread stripping can occur before installation is complete as a result of large friction forces. In order to identify and resolve any potential problems resulting from galvanizing, the ASTM A325 Standard requires that the nut be lubricated and that the assembly be tested to ensure that stripping will not occur at a rotation in excess of that which is required in installation or that twist-off will not take place before the installation is complete.

Overtapping of the nut will usually be done by the manufacturer in order that the coated nut and coated bolt will still assemble properly. This can also be a source of thread stripping. Compliance of the assembly with the rotation test required by the A325 specification will certify that the delivered assembly will perform satisfactorily.

Conformity with all of the relevant requirements of both ASTM A325 and the RCSC Specification will ensure that galvanized bolts and nuts will give satisfactory performance. These requirements include; (1) the galvanized bolts and nuts and washers, if required, must be treated as an assembly, (2) the nuts must have been lubricated and tested with the supplied bolts, (3) the nuts and bolts must be shipped together in the same container, and (4) the supplier is not permitted to supply bolts and nuts that came from different manufacturing sources.

8.6 Reuse of High-Strength Bolts

Occasionally, a bolt that has been installed during the erection process has to be removed and then later reinstalled. This need for reinstallation of bolts might also come up if a structure is taken down and re-erected in a new location. The question arises as to whether high-strength bolts that are required to be pretensioned can be reused, and, if so, how many times.

A certain amount of yielding takes place when a high-strength bolt is installed so that the minimum required pretension is equaled or exceeded. Yielding is confined to a relatively small volume of material located in the threaded region just under the nut. This small amount of yielding is not detrimental to the performance of the bolt [6]. However, if the bolt pretension is

subsequently decreased to zero, e.g., the bolt is loosened, then the question arises as to whether it can be reused.

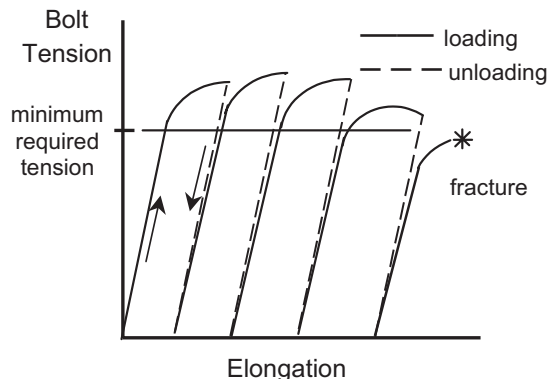

Fig. 8.1 Repeated Installation

The cycle of pretensioning, loosening, and then pretensioning again means that a certain amount of ductility is given up during each cycle. If the number of tightening and loosening cycles is large, then enough ductility will be exhausted so that, eventually, the desired pretension cannot be reached before fracture takes place. Figure 8.1 shows this effect diagrammatically. In the illustration, which is based on test results [6], the minimum required tension was attained upon installation followed by three re-installations (turn-of-nut), but fractured on the fifth attempt.

The research has shown [6] that both A325 and A490 bolts can be reused a small number of times if the water-soluble oily coating that is normally present following the manufacturing process is intact. The tests on A325 bolts showed that at least three or four reinstallations were successful. However, the tests on A490 bolts showed that sometimes only one or two reinstallations were attainable.

The S16 Standard does not offer advice on the reuse of bolts. The RCSC Specification forbids the reuse of both A490 bolts and galvanized A325 bolts. The number of reuses permitted for "black" A325 bolts can be established for a given lot by carrying out a calibration procedure using a Skidmore-Wilhelm calibrator. Of course, the number of reuses must be carefully monitored. As a rule of thumb, if the nut can be made to run freely on the threads by hand only, then reuse is permissible.

It should also be noted that either A325 or A490 bolts that have been snugged and then subsequently found to be loose can be routinely installed as pretensioned bolts. This does not constitute a reuse since thread yielding will not have taken place. Even touch-up of pretensioned bolts in a multi-bolt joint should not generally constitute a reuse, unless the bolt has become substantially unloaded as other parts of the joint are bolted.

8.7 Joints with Combined Bolts and Welds

It is sometimes necessary to use high-strength bolts and fillet welds in the same connection, particularly when remedial work needs to be done. When these elements act in the same shear plane, the combined strength is a function of whether the bolts are snug-tightened or are pretensioned, the orientation of the fillet welds with respect to the direction of the force in the connection, and the location of the bolts relative to their holes. The S16 Standard provides recommendations for the design of such connections in Clause 21.10. However, recent research [55, 56] has shown that these recommendations do not give a good prediction of the actual strength of bolted-welded connections. Although using these rules will give conservative results, they are not based on a rational model.

The approach outlined in [55 and 56] recommends that the joint design strength be taken as the largest of the (1) shear capacity of the bolts only, (2) shear capacity of the welds only, or (3) shear capacity of the combination consisting of the fillet welds and the bolts. High-strength bolts both pretensioned and snug-tight have been explored in the research.

Based on the results of tests of the various combinations, the capacity of a combination of high-strength bolts and fillet welds placed longitudinally with respect to the force, Reference [56] recommends that

$$P_n = (0.50 \times \text{bolt shear resistance}) + (\text{longitudinal weld shear resistance}) + (0.25 \times \text{slip resistance}) \quad (8.1)$$

The bolt shear resistance, the longitudinal weld shear resistance, and the slip resistance are all calculations that are to be made in accordance with the S16 Standard, including the resistance factors (which are not shown in Eq. 8.1).

If bolts and transversely oriented fillet welds are combined, then the capacity is to be taken as

$$P_n = \text{transverse weld shear resistance} + (0.25 \times \text{slip resistance}) \quad (8.2)$$

where the transverse weld shear resistance is now used. Because the amount of deformation that can be accommodated by a transverse fillet weld prior to fracture is very small, the contribution of the bolts in shear is negligible and is taken here as zero. Once the transverse weld has reached its ultimate capacity (i.e., when it fractures), then the situation simply reverts to that of a bolted joint. This strength may be greater than that given by Eq. 8.2, depending on the proportion of bolts to transverse weld.

When bolts are combined with both longitudinal and transverse welds, the capacity is to be taken as

$$\begin{aligned}
P_n = & (0.85 \times \text{long. weld shear resistance}) \\
& + (\text{transverse weld shear resistance}) \quad (8.3) \\
& + (0.25 \times \text{slip resistance})
\end{aligned}$$

Once again, it is recognized that the transverse weld will reach its ultimate strength at a relatively small amount of deformation. Once it breaks, the situation reverts to that of a longitudinal fillet weld in combination with high-strength bolts. Now, Eq. 8.1 applies and the strength calculated in this way could be larger than that obtained using Eq. 8.3.

Overriding all these cases, it has already been noted that it is possible that the weld shear strength alone can govern or that the bolt shear strength alone can govern. The practical meaning of such a situation is that there can be no benefit when considering certain combinations of bolts and welds. These cases will arise when the proportions of welds and bolts are inappropriate. Consider, for example, an existing bolted joint to which only a small amount of longitudinal weld is added. As the joint is loaded, the bolts are not fully effective in shear, in accordance with Eq. 8.1. As the longitudinal weld reaches its ultimate capacity and fractures, the situation reverts to that of a bolted joint alone. The bolts are now fully effective and their strength can be greater than the combined bolted-welded strength. In total, the designer has to check these situations (bolts alone or welds alone) plus the appropriate equations among Eq. 8.1, 8.2, and 8.3.

Generally, the addition of transverse fillet welds to a bolted joint is not an very effective way of strengthening an existing joint.

8.8 Surface Coatings

In some applications, it is advisable to provide a protective coating to the surface of the steel used in the structure. The main reason for doing so is to prevent corrosion of the steel, either for when the steel is exposed during the erection phase or for protection on a continuing basis. Coatings can be paint, a metallic layer of zinc or aluminum, various kinds of vinyl washes, organic or inorganic zinc-rich paints, and so on. If the coating is applied to the surfaces of joints that are designated as snug-tightened [18], then the coating has no influence upon the strength or performance of the connection. In these cases, the strength of the joint is determined on the basis of the net section of the connected material, on the shear strength of the bolts, or on the bearing strength of the connected material. It is only when the joint is designated and designed as slip-critical that the coating plays a role.

The design of slip-critical joints was described in Section 5.2. As explained there, the slip coefficient of the steel, k_s , enters directly into the design equation (Eq. 5.3). Values of k_s are given in Table 3 of the S16 Standard for three different surface conditions. For example, a hot-dip galvanized surface that has been roughened (by light hand wire brushing) has a prescribed slip value $k_s = 0.40$. In all cases where coatings other than those listed are used, the S16 Standard requires that tests be carried out to determine the slip coefficient for that case. The method of test is given in the RCSC Specification [15].

REFERENCES

1. Bibliography on Bolted and Riveted Joints, ASCE Manuals and Reports on Engineering Practice, No. 48, American Society of Civil Engineers, Reston, VA.,
2. Bibliography on Riveted Joints, A.E.R. deJong, American Society of Mechanical Engineers, New York, 1945.
3. C. Batho and E.H. Bateman, "Investigations on Bolts and Bolted Joints, Second Report of the Steel Structures Research Committee," London, 1934.
4. W.M. Wilson and F.P. Thomas, "Fatigue Tests on Riveted Joints," Bulletin 302, Engineering Experiment Station, University of Illinois, Urbana, 1938.
5. Research Council on Riveted and Bolted Structural Joints of the Engineering Foundation, Specifications for Assembly of Structural Joints Using High-Strength Bolts, 1951.
6. G.L. Kulak, J.W. Fisher, and J.A.H. Struik, *Guide to Design Criteria for Bolted and Riveted Joints*, Second Edition, John Wiley, New York, 1987.
7. *Connections in Steel Structures: Behaviour, Strength, and Design*, Elsevier Applied Science, 1988, Editors: Reidar Bjorhovde, Jacques Brozzetti, and Andre Colson
8. *Connections in Steel Structures II: Behavior, Strength, and Design*, American Institute of Steel Construction, 1991. Editors: Reidar Bjorhovde, Andre Colson, Geerhard Haaijer, and Jan Stark.
9. *Connections in Steel Structures III: Behaviour, Strength, and Design*, Pergamon, 1996. Editors: Reidar Bjorhovde, Andre Colson, and Riccardo Zandonini.
10. *Connections in Steel Structures IV: Behavior, Strength and Design*, American Institute of Steel Construction, 2002. Editors: R. T. Leon and W.S. Easterling.
11. ASTM A502-93, Standard Specification for Steel Structural Rivets, American Society for Testing and Materials, West Conshohocken, Pennsylvania, USA.
12. ASTM A307-00, Standard Specification for Carbon Steel Bolts and Studs, 60 000 PSI Tensile Strength, American Society for Testing and Materials, West Conshohocken, Pennsylvania, USA.
13. ASTM A325-02, Standard Specification for Structural Bolts, Steel, Heat Treated, 102/105 ksi Minimum Tensile Strength, American Society for Testing and Materials, West Conshohocken, Pennsylvania, USA.
14. ASTM A490-02, Standard Specification for Structural Bolts, Alloy Steel, Heat-Treated, 150 ksi Minimum Tensile Strength, American Society for Testing and Materials, West Conshohocken, Pennsylvania, USA.
15. Load and Resistance Factor Design Specification for Structural Joints Using ASTM A325 or A490 Bolts, Research Council on Structural Connections, 2000. (Available free at www.boltcouncil.org).
16. ASTM A563-00, Standard Specification for Carbon and Alloy Steel Nuts, American Society for Testing and Materials, West Conshohocken, Pennsylvania, USA.
17. ASTM F436-93(2000), Standard Specification for Hardened Steel Washers, American Society for Testing and Materials, West Conshohocken, Pennsylvania, USA.
18. Canadian Standards Association, CAN/CSA-S16-01 Limit States Design of Steel Structures, Toronto, 2001.
19. G.L. Kulak and G.Y. Grondin, *Limit States Design in Structural Steel*, Seventh Edition, Canadian Institute of Steel Construction, Toronto, 2002.
20. Canadian Standards Association, CAN/CSA-S6-00 *Canadian Highway Bridge Design Code*, Toronto, 2000.
21. L. Shenker, C.G. Salmon, and B.G. Johnston, "Structural Steel Connections," Department of Civil Engineering, University of Michigan, Ann Arbor, 1954.
22. Fisher, J.W., Galambos, T.V., Kulak, G.L., and Ravindra, M.K., "Load and Resistance Factor Design Criteria for Connectors," J. of the Structural Division, ASCE, Vol. 104, No. ST9, September 1978.
23. Munse, W.H. and Cox, H.C., "The Static Strength of Rivets Subjected to Combined Tension and Shear," Engineering Experiment Station Bulletin 427, University of Illinois, Urbana, 1956.
24. Hechtman, R.A., "A Study of the Effects of Heating and Driving Conditions on Hot-Driven Structural Steel Rivets," Department of Civil Engineering, University of Illinois, Urbana, 1948.

25. Yoshida, N. and Fisher, J.W., "Large Shingle Splices that Simulate Bridge Joints," Fritz Engineering Laboratory Report No. 340.2, Lehigh University, Bethlehem, PA, December, 1968.
26. Rumpf, John L. and Fisher, John W., "Calibration of A325 Bolts," J. of the Structural Division, ASCE, Vol. 89, ST6, December, 1963.
27. Christopher, R.J., Kulak, G.L., and Fisher, J.W., "Calibration of Alloy Steel Bolts," J. of the Structural Division, ASCE, Vol. 92, ST2, April, 1966.
28. Bickford, John H., "An Introduction to the Design and Behavior of Bolted Joints," Second Edition, Marcel Dekker Inc., New York, 1990.
29. Kulak, G.L. and Birkemoe, P.C., "Field Studies of Bolt Pretension," J. Construct. Steel Research, Vol. 25, Nos. 1 & 2, pages 95-106, 1993.
30. ASTM F1852-00, Standard Specification for "Twist Off" Type Tension Control Structural Bolt/Nut/Washer Assemblies, Steel, Heat Treated, 120/105 ksi Minimum Tensile Strength, American Society for Testing and Materials, West Conshohocken, Pennsylvania, USA.
31. Kulak, Geoffrey L. and Undershute, Scott T., "Tension Control Bolts: Strength and Installation," Journal of Bridge Engineering, Vol. 3 No. 1, ASCE, February, 1998.
32. ASTM F959-99a, Standard Specification for Compressible-Washer-Type Direct Tension Indicators for Use with Structural Fasteners, American Society for Testing and Materials, West Conshohocken, Pennsylvania, USA.
33. Dahl, Joan S., Le-Wu Lu, Fisher, John W., and Abruzzo, John, "Comparative Effectiveness of Tightening Techniques for A490 1-1/4 in. Diameter Bolts," Engineering Journal, American Institute of Steel Construction, Vol. 33, No. 1, First Quarter, 1996.
34. Oswald, C.J., Dexter, R.J., Brauer, S.K., "Field Study of Pretension in Large Diameter A490 Bolts," ASCE Journal of Bridge Engineering, Vol. 1, August, 1996.
35. Mikkel A. Hansen, "Influence of Undeveloped fillers on Shear Strength of Bolted Splice Joints," PSFSEL Thesis No. 80-1, Department of Civil Engineering, The University of Texas at Austin, March, 1980.
36. Yura, J.A., Frank, K.H., and Polyzois, D., "High Strength Bolts for Bridges," PMFSEL Report No. 87-3, Department of Civil Engineering, The University of Texas at Austin, May, 1987.
37. Load and Resistance Design Specification for Structural Steel Buildings, American Institute of Steel Construction, Chicago, Illinois, 1999.
38. Chesson, Eugene, Jr., Munse, William H., and Faustino, Norberto R., "High-Strength Bolts Subjected to Tension and Shear," Journal of the Structural Division, ASCE, Vol. 91, ST5, October, 1965.
39. Chesson, Eugene, Jr., "Bolted Bridge Behavior During Erection and Service," Journal of the Structural Division, ASCE, Vol. 91, ST3, June, 1965.
40. Kulak, Geoffrey L. and Grondin, G.Y., "AISC LRFD Rules for Block Shear in Bolted Connections—A Review," Engineering Journal, American Institute of Steel Construction, Vol. 38, No. 4, Fourth Quarter, 2001. (See also Errata to this reference.)
41. Driver, R.G, Grondin, G.Y., and Kulak, G.L., "A Unified Approach to Design for Block Shear," Proc. Connections in Steel Structures V, Amsterdam, June, 2004.
42. Munse, W.H. and Chesson, E. Jr., "Riveted and Bolted Joints: Net Section Design," J. of the Struct. Div., ASCE, Vol. 89 (1), 107-126, 1963.
43. Chesson, E., Jr., and Munse, W.H., "Riveted and Bolted Joints: Truss Type Tensile Connections," J. of the Struct. Div., ASCE, Vol. 89 (1), 67-106, 1963.
44. McGuire, William, "Steel Structures," Prentice-Hall Inc., Englewood Cliffs, N.J., 1968.
45. Canadian Institute of Steel Construction, "Handbook of Steel Construction," Eighth Edition, Willowdale, Ontario, 2004.
46. Fisher, J.W., Kulak, G.L., and Smith, I.F.C., "A Fatigue Primer for Structural Engineers," National Steel Bridge Alliance, American Institute of Steel Construction, Chicago, IL., 1998.
47. Fisher, J.W., Yen, B.T. and Wang D., "Fatigue of Bridge Structures – a Commentary and Guide for Design, Evaluation and Investigation Of Cracking," ATLSS Report No 89-02, Lehigh University, Bethlehem, PA, 1989.
48. Kulak, G.L., "Fatigue Strength of Riveted Shear Splices," Progress in Structural Engineering and Materials, Vol 2 (1), 1-10, 2000.
49. Dexter, J. Robert, Wright, W.J., and Fisher, J.W., "Fatigue and Fracture of Steel Girders," J. of Bridge Engineering, ASCE, Vol. 9, No. 3, May, 2004.

50. Josi, Georg, Grondin, Gilbert Y., and Kulak, Geoffrey L., "Fatigue of Joints with Staggered Holes," *Journal of Bridge Engineering*, Vol. 9, No. 6, November–December 2004.
51. American Association of State Highway and Transportation Officials, "AASHTO LRFD Bridge Design Specifications, SI, 3rd Edition," Washington, D.C., 2004.
52. Nair, R.S., Birkemoe, P.C., and Munse, W.H., "High Strength Bolts Subjected to Tension and Prying," *J. of the Structural Division, ASCE*, Vol. 100, No. ST2, February, 1974.
53. Bouwman, L.P., "Fatigue of Bolted Connections and Bolts Loaded in Tension," Report No. 6–79–9, Stevin Laboratory, Delft Univ. of Technology, Delft, The Netherlands, 1979.
54. *Structural Bolting Handbook*, Steel Structures Technology Center, Inc. Novi, MI., 2000.
55. Manuel, Thomas J. and Kulak, Geoffrey L., "Strength of Joints that Combine Bolts and Welds," *Journal of Structural Engineering, ASCE*, Vol. 126, No. 3, March, 2000.
56. Kulak, Geoffrey L. and Grondin, G.Y., "Strength of Joints that Combine Bolts and Welds," *Engineering Journal, American Institute of Steel Construction*, Vol. 40, No. 2, Second Quarter 2003.

INDEX

- Anchor rods (anchor bolts), 2
- American Society for Testing and Materials (see ASTM)
- Arbitration inspection, 21
- ASTM (bolt and related specifications)
 - A141, 10
 - A193, 4
 - A307, 3
 - A325, 3, 13
 - A354BD, 4
 - A449, 4
 - A490, 3, 13
 - A502, 2
 - A563, 4
 - F436, 45
 - F1852, 13, 45
- Bearing
 - bearing stresses, 6, 31
- Bearing-type joints, 6, 30,
- Block shear (see Tension and shear block)
- Bolts
 - Bolt length, 46
 - Combined shear and tension, 25
 - Combined with welds, 48
 - Fatigue strength, 41, 43
 - Galvanized, 47
 - High-strength, 3
 - Historical notes, 1
 - Installation (see Installation of bolts)
 - Long, 16, 47
 - Mechanical properties, 3, 13
 - Ordinary, or, common (A307), 3
 - Pretension (see Pretension)
 - Proof load, 13
 - Reuse, 47
 - Rotation capacity, 16
 - Shear strength, 6, 24
 - Short, 47
 - Tensile strength, 23, 35
- Butt splice, 27
- Calibrated wrench installation, 17
- Calibration of bolts, 17
- Canadian Standards Association
 - CAN/CSA – S06, 7
 - CAN/CSA – S16, 7
- Clamping force (see pretension)
- Coatings, 48
- Combined bolted-welded joints, 48
- Combined tension and shear, 5, 10, 25
- Common bolts (A307), 3
- Connections
 - Butt splice, 27
 - Gusset plate, 4
 - Tension-type, 5
- Design philosophy, 6
- Direct tension indicators, 18, 45
- End distance, 31
- Factored resistance, 7
- Fatigue
 - AASHTO specification, 42
 - Fretting, 41
 - Riveted connections, 41
 - Shear-type bolted connections, 42
 - Tension-type bolted connections, 43
- Galvanized bolts and nuts, 47
- Grip length, 16
- High-strength bolts
 - ASTM A307, 3
 - ASTM A325, 3, 13
 - ASTM A354BD, 4
 - ASTM A449, 4
 - ASTM A490, 3
 - ASTM F1852, 17
 - Direct tension strength, 23, 35
 - Fatigue, 39
 - Galvanized, 47
 - Historical review, 1
 - Installation (see Installation of bolts)
 - Load vs. deformation in shear, 24
 - Load vs. deformation in tension, 23
 - Mechanical properties, 3, 13
 - Reuse (reinstallation), 47
 - Shear strength, 24
 - Tension control bolts, 17
 - Torqued tension, 14
- Historical notes, 1
- Holes
 - Oversize holes, 45
 - Slotted holes, 45
- Inspection
 - Arbitration, 21
 - Direct tension indicators, 21
 - General requirements, 20
 - Pretensioned bolts, 20
 - Snug-tightened bolts, 20
 - Twist-off bolts, 20
- Installation of bolts
 - Calibrated wrench, 17
 - General requirements, 13
 - Load-indicating washers, 18
 - Tension-control bolts, 18
 - Turn-of-nut, 14
 - Washers, 16, 45
- Joint length effect, 27
- Joint type (shear splices)
 - Bearing-type

- Pretensioned bolts, 20
 - Slip-critical, 20, 27
 - Snug-tightened bolts, 20
- Lap splice, 4
- Limit states
 - Ultimate, 6
 - Serviceability, 7
- Load factor, 7
- Load indicating washers, 19
- Load transfer concepts, 4
- Long bolts, 16, 46
- Mechanical fasteners
 - Bolts, 3
 - Rivets, 1, 9
- Nominal resistance, 7
- Nuts
 - Galvanized, 47
 - General, 13
 - Specifications, 4
- Oversize holes, 45
- Pretension
 - Calibrated wrench installation, 17
 - Direct tension indicators, 18
 - Effect of bolt length, 16, 46
 - Effect of external load, 35
 - Effect of hole size, 45
 - High-strength bolts, 4, 13, 15
 - Load-indicating washers, 19
 - Ordinary bolts (A307), 3
 - Rivets, 2, 9
 - Selection of joint type
 - Slip resistance, 28
 - Tension-control bolts, 18
 - Turn-of-nut installation, 17
 - Washer requirements, 16, 45
- Prying forces, 37
- Reinstallation of high-strength bolts, 47
- Reuse of high-strength bolts, 47
- Research Council on Structural Connections (RCSC)
 - History, 1
 - Specifications, 3
- Resistance factor, 7
- Rivets
 - Clamping force, 2
 - Combined shear and tension, 10
 - Fatigue strength, 39
 - Grades, 2
 - History, 1
 - Installation, 2
 - Mechanical properties, 2
 - Prying, 9
 - Shear strength, 9
 - Tensile strength, 9
- Serviceability limit state, 7
- Shear (in fasteners)
 - Combined shear and tension, bolts, 25
 - Combined shear and tension, rivets, 10
 - Effect of joint length, 25
 - Effect of pretension, 15, 25
 - Effect of threads, 25
 - Shear strength of bolts, 24, 30
 - Shear strength of rivets, 9
- Shear lag, 32
- Slip in joints, 27
- Slip-critical joints, 19, 28
- Slip coefficient, 29
- Slip resistance, 29
- Short bolts, 46
- Slotted holes, 45
- Snug-tightened bolts, 13, 19
- Stress area, 2
- Surface coatings, 49
- Tension and shear block, 31
- Tensile stress area, 2, 24
- Tension-control bolts, 17
- Tension strength of bolts, 23, 35
- Tension strength of rivets, 9
- Tension-type connections, 5, 35
- Threaded rods, 2
- Torque vs. tension relationship, 17
- Truss-type connections, 4
- Turn-of-nut method of installation, 14
- Washers
 - Load-indicating washers, 18
 - Oversize holes, 45
 - Slotted holes, 45
 - Standard holes, 45
 - Standard washers, 16, 45

Canadian Institute of Steel Construction
300-201 Consumers Road
Willowdale, ON M2J 4G8
Tel 416-491-4552 Fax 416-491-6461
www.cisc-icca.ca

ISBN 0-88811-109-6